

# EK-PRO GPU WB H100 NVL Rack - Nickel + Inox

GPU WATER BLOCK

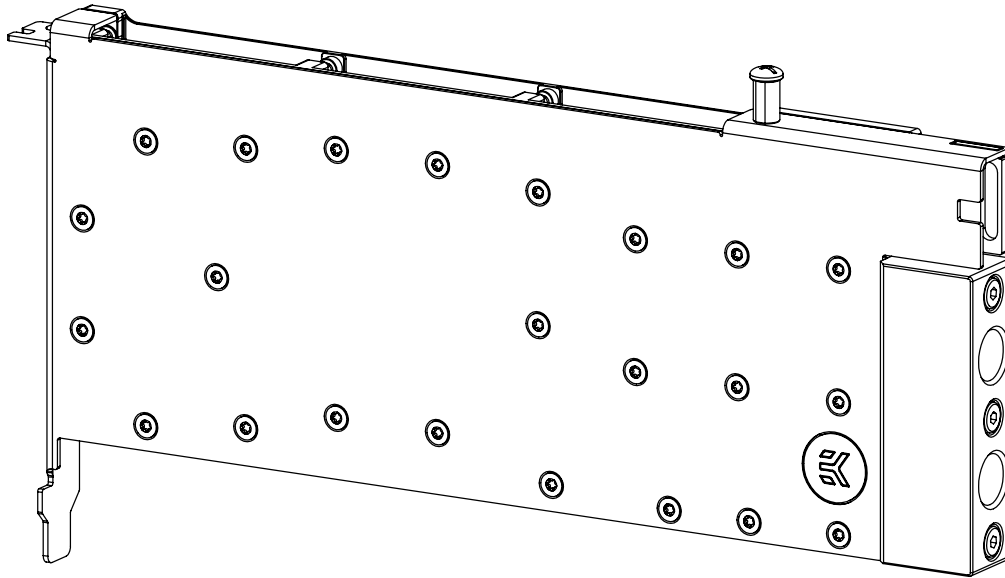

Before you start using this product, please follow these basic guidelines:

Carefully read the manual before beginning with the installation process.

Remove your graphics card from the computer for the safest mounting process to prevent any possible damage to your GPU or its circuit board (PCB).

EK Fittings require only a small amount of force to screw them firmly in place since the liquid seal is ensured with the rubber O-ring gaskets.

The use of quality market-proven corrosion-inhibiting coolants is always strongly recommended for any liquid cooling system.

Do not use pure distilled water as a cooling liquid! For best results, EK recommends the use of EK-CryoFuel Coolants. Make sure to bleed air out of your water block thoroughly in order to reach optimal performance.

# TABLE OF CONTENTS

BOX CONTENTS .....	4
WATER BLOCK DIMENSIONS .....	5
TECHNICAL SPECIFICATIONS AND WATER BLOCK PARTS .....	6
PREPARING YOUR GRAPHICS CARD .....	7
REMOVING THE STOCK COOLER .....	7
CLEANING THE PCB .....	7
CUTTING AND PLACING THERMAL PADS .....	8
APPLYING THERMAL COMPOUND .....	9
INSTALLING THE WATER BLOCK .....	9
PLACING THE BLOCK ON THE GRAPHICS CARD .....	9
CHECKING THE CONTACT IN CASE OF HIGH TEMPERATURES .....	11
ATTACHING THE WATER BLOCK .....	11
INSERTING THE GRAPHICS CARD INTO THE CHASSIS .....	12
TESTING THE LOOP .....	12
SUPPORT AND SERVICE .....	13
SOCIAL MEDIA .....	13

# BOX CONTENTS

099 - Mounting H100 Rack (1x) EAN: 107239  
 Note: There are additional screws in the mounting kit.

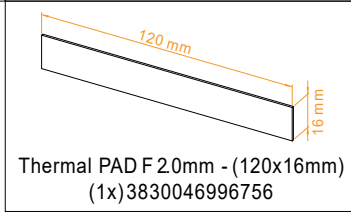
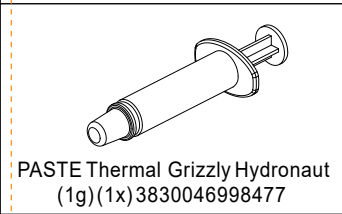
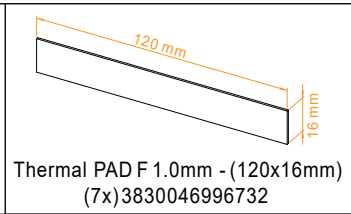
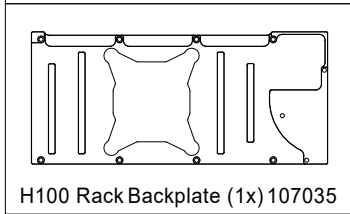
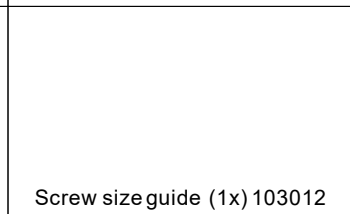
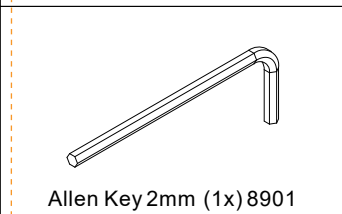
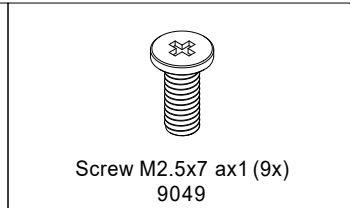
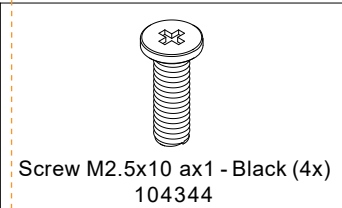
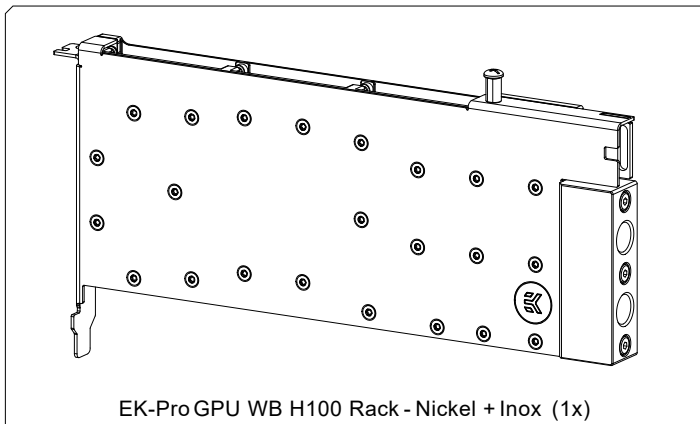

# WATER BLOCK DIMENSIONS

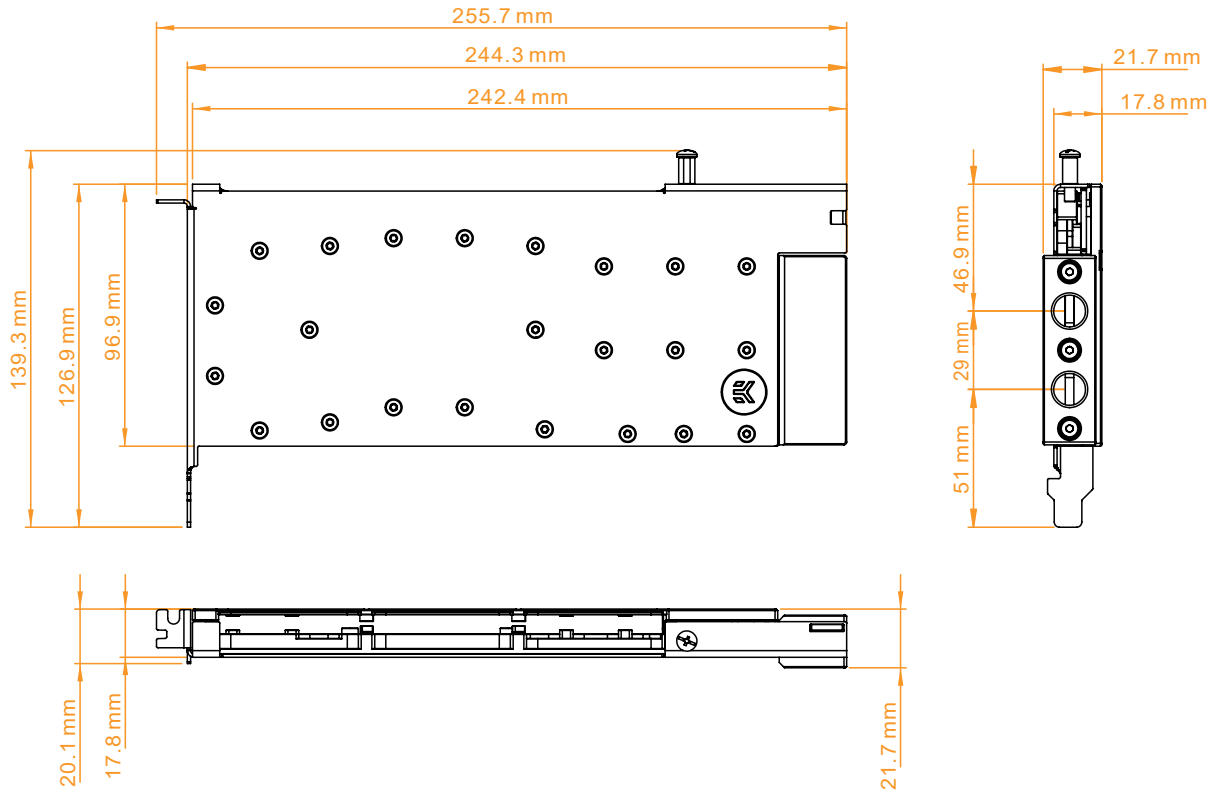

## TECHNICAL SPECIFICATIONS AND WATER BLOCK PARTS

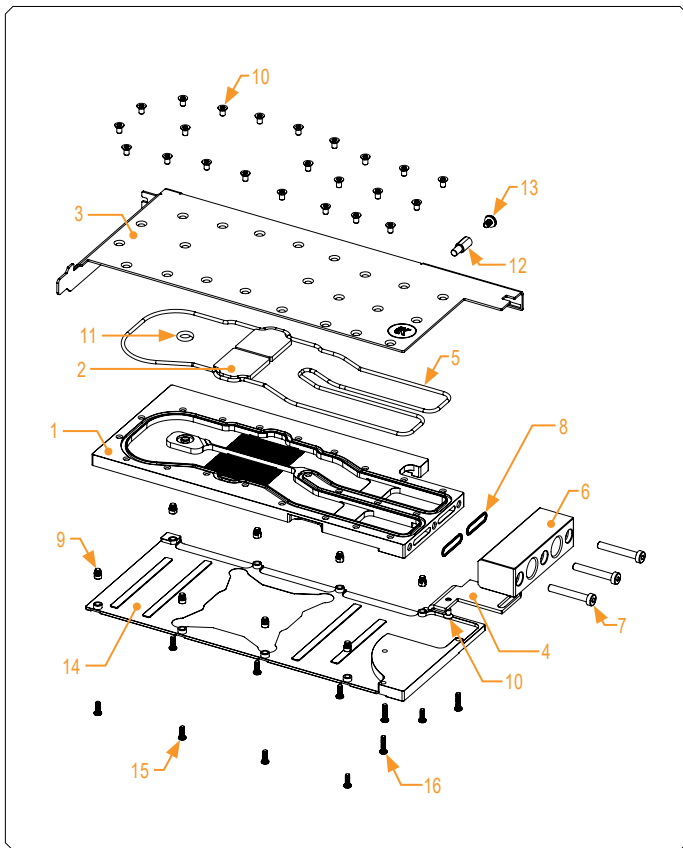

Position	EAN	Description	Quantity
1	107884	H100 NVL Rack Coldplate (Ni)	1
2	107041	H100 Rack Insert	2
3	107036	H100 RackPro Top	1
4	107037	H100 RackPower Adapter	1
5	107064	OR - H100 Rack	1
6	103767	Top acetal - FC terminal Direct	1
7	100006	Screw M4x27 DIN7984	3
8	5155	OR 15x1 EPDM50 (FCTerminal)	2
9	103987	Standoff M3.5-M2.5 x 3	8
10	103089	Screw M3x5 ISO 14581 TX	24
11	107088	OR 6x2 EPDM	1
12	102490	Bracket standoff M4-6/32 - Ni	1
13	8483	Screw ISO 7380 - UNC6-32 x 5	1
14	107035	H100 Rack Backplate (Bl. Elox)	1
15	9049	Screw M2.5x7 ax1	8
16	104344	Screw M2.5x10 ax1	3

## PREPARING YOUR GRAPHICS CARD

### STEP 1

#### REMOVING THE STOCK COOLER

Place your graphics card on the flat surface and carefully remove the stock cooler. Do not forget to unplug all the LED and fan connectors. Pay attention to the following steps in order to install the EK-Pro GPU WB H100 Rack - Nickel + Inox water block onto the graphics card.

### STEP 2

#### CLEANING THE PCB

Wipe off the remains of the original thermal compound using a nonabrasive cloth or Q-tip, as shown in the sample image, until the components and circuit board are completely clean. EK recommends the use of denatured alcohol for removing TIM leftovers. After that, remove all remaining stock thermal pads from the PCB.v

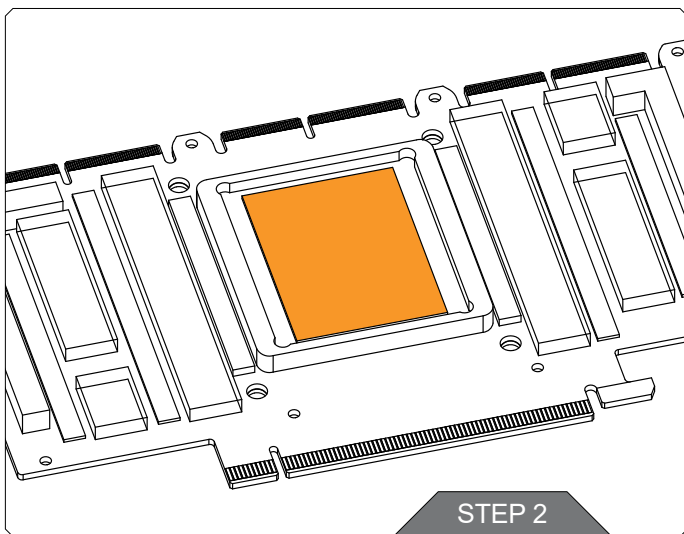

## CUTTING AND PLACING THERMAL PADS

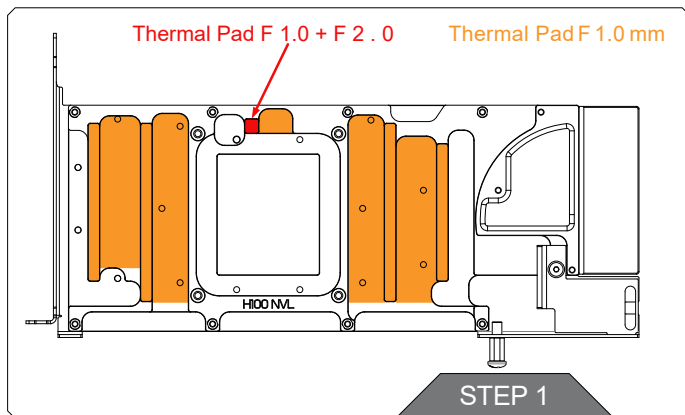

### STEP 1

Your GPU water block comes with un-cut thermal pads to cover all the VRM components, such as COILs, MOSFETs, and drivers. Please use 1.0 mm thick thermal pads which should be placed on the water block, as illustrated. Stack 1.0 mm and 2.0 mm thermal pad on a surface marked with a red color. EK made sure to provide you with more than an adequate quantity of thermal pads to complete This Step.



You must remove the protective foil from both sides of the thermal pad before installation.

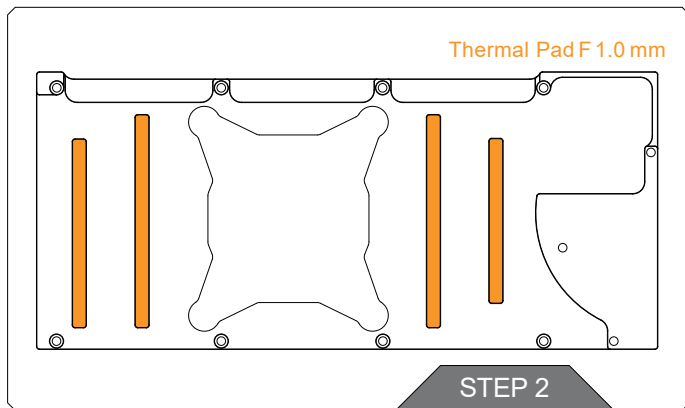

### STEP 2

Please use 1.0 mm thick thermal pads which should be placed on the backplate, as illustrated below. EK made sure to provide you with more than an adequate quantity of thermal pads to complete this Step.



You must remove the protective foil from both sides of the thermal pad before installation.



## APPLYING THERMAL COMPOUND

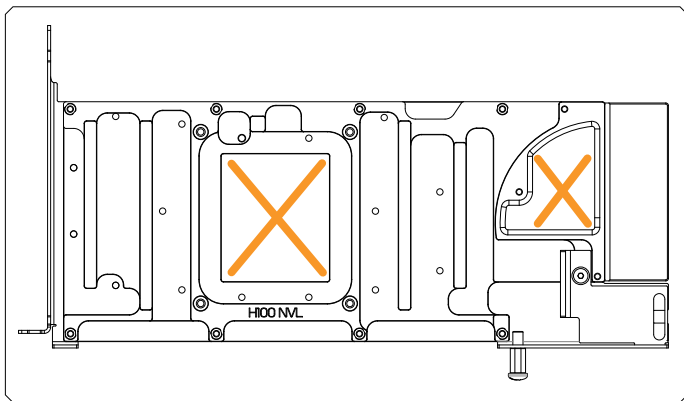

Apply the enclosed EK-TIM Ectotherm thermal grease (thermal compound) on the GPU heat spreader – IHS – as shown in the image. The layer of the thermal compound must be thin and even over the entire surface of the IHS.



The excessive or uneven application of thermal grease may lead to poor performance!

For this Step, you will need:

Thermal Grease

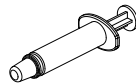

## INSTALLING THE WATER BLOCK

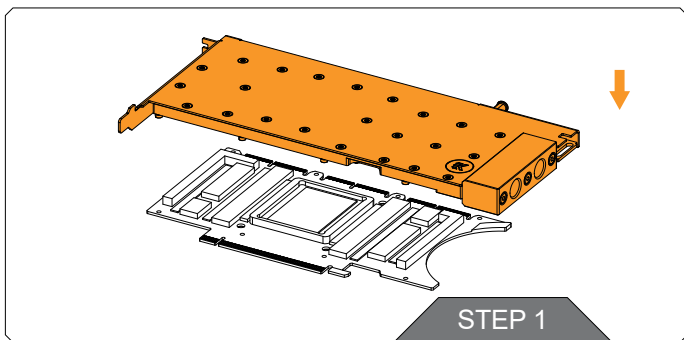

STEP 1

### PLACING THE BLOCK ON THE GRAPHICS CARD

This procedure is the same for all full-cover water blocks. Carefully position the water block with preinstalled standoffs on the graphics card. During this process, make sure you have aligned mounting holes of the PCB with holes of the water block.



Pay attention not to use too much force when pressing the block down to the PCB since chip dies are prone to cracking.

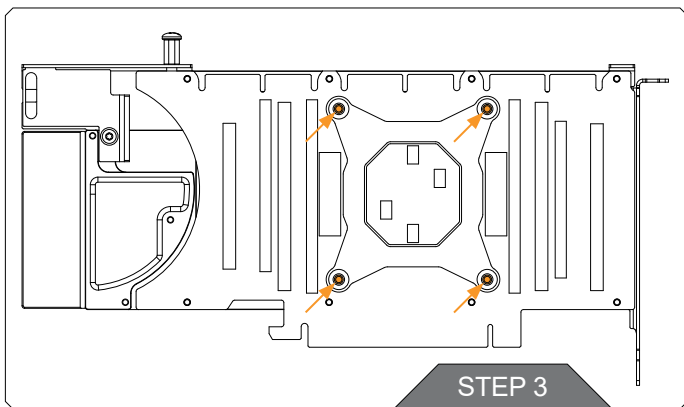

### STEP 3

Use stock cross backplate from the original card and mount it with original stock M3 screws.

STEP 3

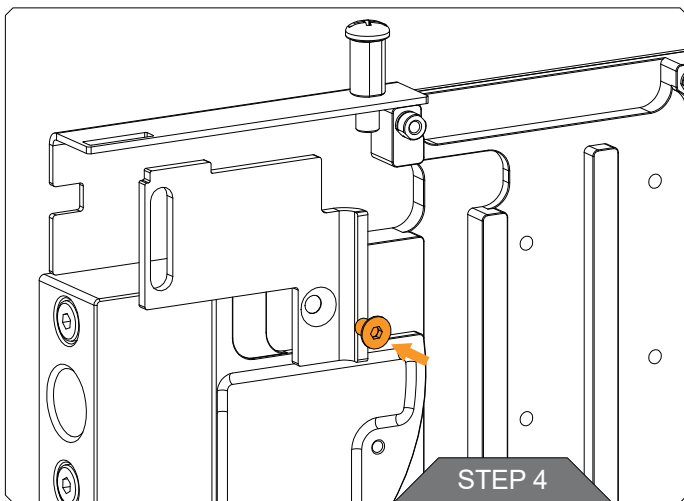

### STEP 4

Secure power cable with mounting it into included inox power adapter.

### STEP 4b

Insert 8-pin power connector in to the inox adapter. Pads on the power adapter must be alligned with openings in inox power adapter.

Pay attention to the orietation of the latch on connector.

For this Step, you will need:

Allen Key 2mm (1x) 8901

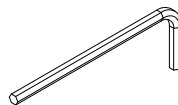

STEP 4

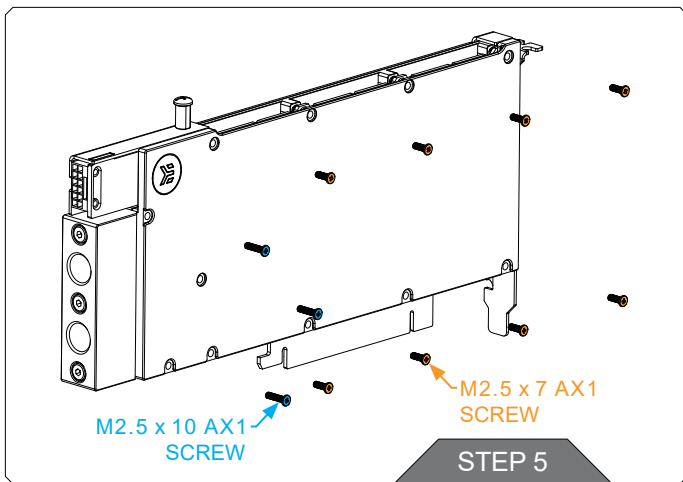

## STEP 5

### ATTACHING THE WATER BLOCK

Use eight (8) M2.5 x 7 AX1 and three (3) M2.5 x 10 AX1 screws. Tighten the screws evenly using the Phillips head screwdriver. EK recommends you start tightening the screws around the GPU core first and then continuing outward to prevent damage to the GPU. The screws must be present on the places marked below:

For this Step, you will need:

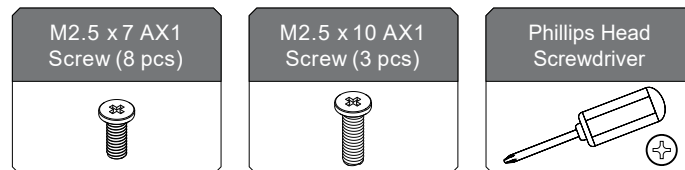

## CHECKING THE CONTACT IN CASE OF HIGH TEMPERATURES

If necessary, temporarily remove the water block to check for uniform surface contact between the block and components. Pay special attention to the VRM section of the graphics card. Check whether the water block makes contact with the intended integrated circuit. Then repeat Steps from the previous section to re-attach the block.



In case you fail to obtain good contact, please check again or contact our support service at <https://www.ekwb.com/customer-support/>.

## INSERTING THE GRAPHICS CARD INTO THE CHASSIS

Carefully lift your graphics card with the installed water block and insert it into your PC's motherboard PCI express expansion slot. Please keep in mind that your graphics card is heavier than before it was equipped with the water block.



You need to be very careful when handling the graphics card. Avoid all unnecessary manipulation of the water block assembly that might damage your card or water block.

## TESTING THE LOOP

To ensure the installation of EK components was successful, we recommend you perform a 24-hour leak test.

When your loop is complete and filled with coolant, connect the pump to a PSU outside your system. Do not connect power to any of the other components. Turn on the PSU and let the pump run continuously.

Inspect all parts of the loop, and in case the coolant leaks, fix the issue and repeat the testing process. To prevent possible damage, please ensure all hardware is dry before the system is powered on.

## SUPPORT AND SERVICE

In case you need assistance or wish to order spare parts or a new mounting mechanism, please contact:

<https://www.ekwb.com/customer-support/>

For spare parts orders, refer to the page with “TECHNICAL SPECIFICATIONS AND WATER BLOCK PARTS” where you can find the EAN number of each part you might need.

Include the EAN number with quantity in your request. Mounting Mechanism EAN can be found under “BOX CONTENTS”

Thermal pads are readily available in the EKshop

## SOCIAL MEDIA

 EKWaterBlocks

 @EKWaterBlocks

 ekwaterblocks

 EKWBofficial

 ekwaterblocks

