

EK-Quantum Momentum² ROG Crosshair X670E Hero D-RGB

MONOBLOCK

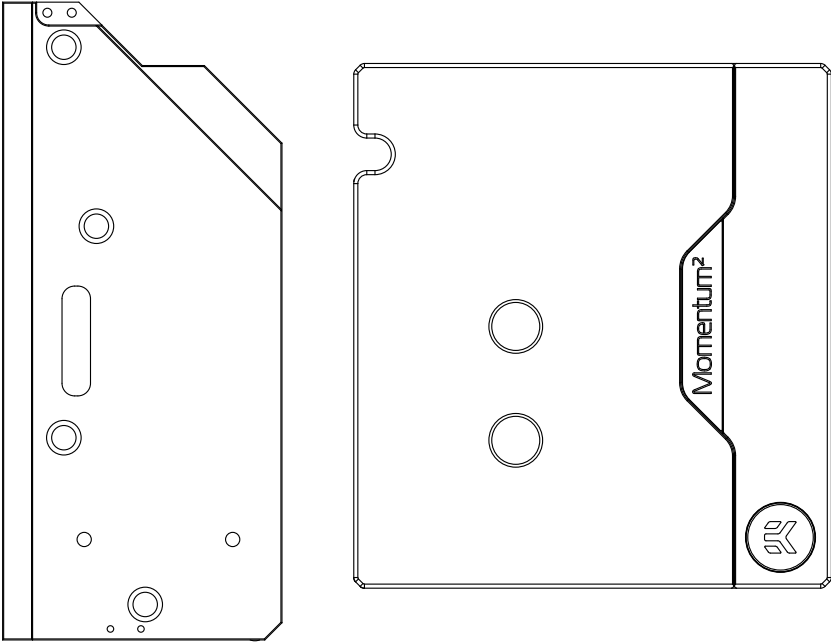

Please note the installation of the product is intended to be undertaken by an adequately trained and experienced person. You are installing the product at your own risk. If you are not properly trained or experienced or feel unsure about the installation procedure, please refrain from installing the product yourself and contact our tech support for assistance. We disclaim our liability for any damages to the product as well as incidental, consequential, or indirect damages incurred due to improper or inappropriate installation.

Before you start using this product, please follow these basic guidelines:

Please carefully read the manual before beginning the installation process.

The EK Fittings require only a small amount of force to screw them firmly in place since the liquid seal is ensured by the rubber O-ring gaskets.

The use of corrosion-inhibiting coolants is always recommended for liquid cooling systems, and mandatory for nickel-plated water blocks.



Do not use pure distilled water! For best results, EK recommends the use of EK-Cryo Fuel coolants.

Make sure to thoroughly bleed air out of your water block, or you will not reach optimal performance.

TABLE OF CONTENTS

BOX CONTENTS	4
WATER BLOCK DIMENSIONS	5
TECHNICAL SPECIFICATIONS AND WATER BLOCK PARTS	6
PREPARING THE MOTHERBOARD	7
REMOVING THE STOCK COOLER	7
PREPARING THE REPLACEMENT COVER	9
INSTALLING THE WATER BLOCK	11
CUTTING AND PLACING THERMAL PADS	11
INSTALLING AND CLEANING THE CPU	12
APPLYING THERMAL COMPOUND	12
FITTINGS AND TUBING	15
CONNECTING THE D-RGB LED STRIP	15
TESTING THE LOOP	16
WARRANTY	16
SUPPORT AND SERVICE	17
SOCIAL MEDIA	17

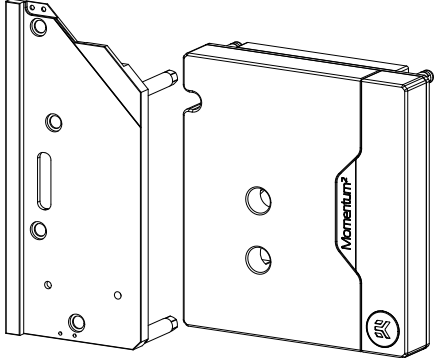
BOX CONTENTS

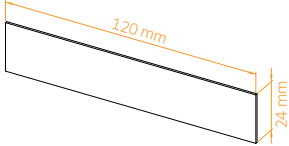
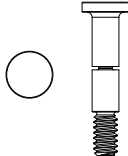
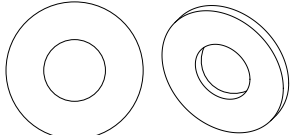
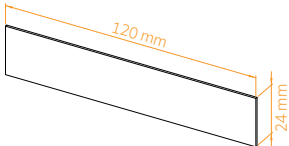
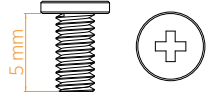
 <p>EK-Quantum Momentum² ROG Crosshair X670E Hero D-RGB</p>	 <p>Allen Key 2.5 mm (1 pc)</p>	 <p>Allen Key 2 mm (1 pc)</p>
 <p>Thermal Pad G 0.5 mm (120 x 24 mm) (1 pc)</p>	 <p>Velocity² Mounting Screw AM5 (Ni) (1 pc)</p>	 <p>Polyamide Washer M2.5 0.5 mm (3 pcs)</p>
 <p>Thermal Pad G 1.5 mm (120 x 24 mm) (1 pc)</p>		 <p>M2.5x5 AX1 Screw (3 pcs)</p>

WATER BLOCK DIMENSIONS

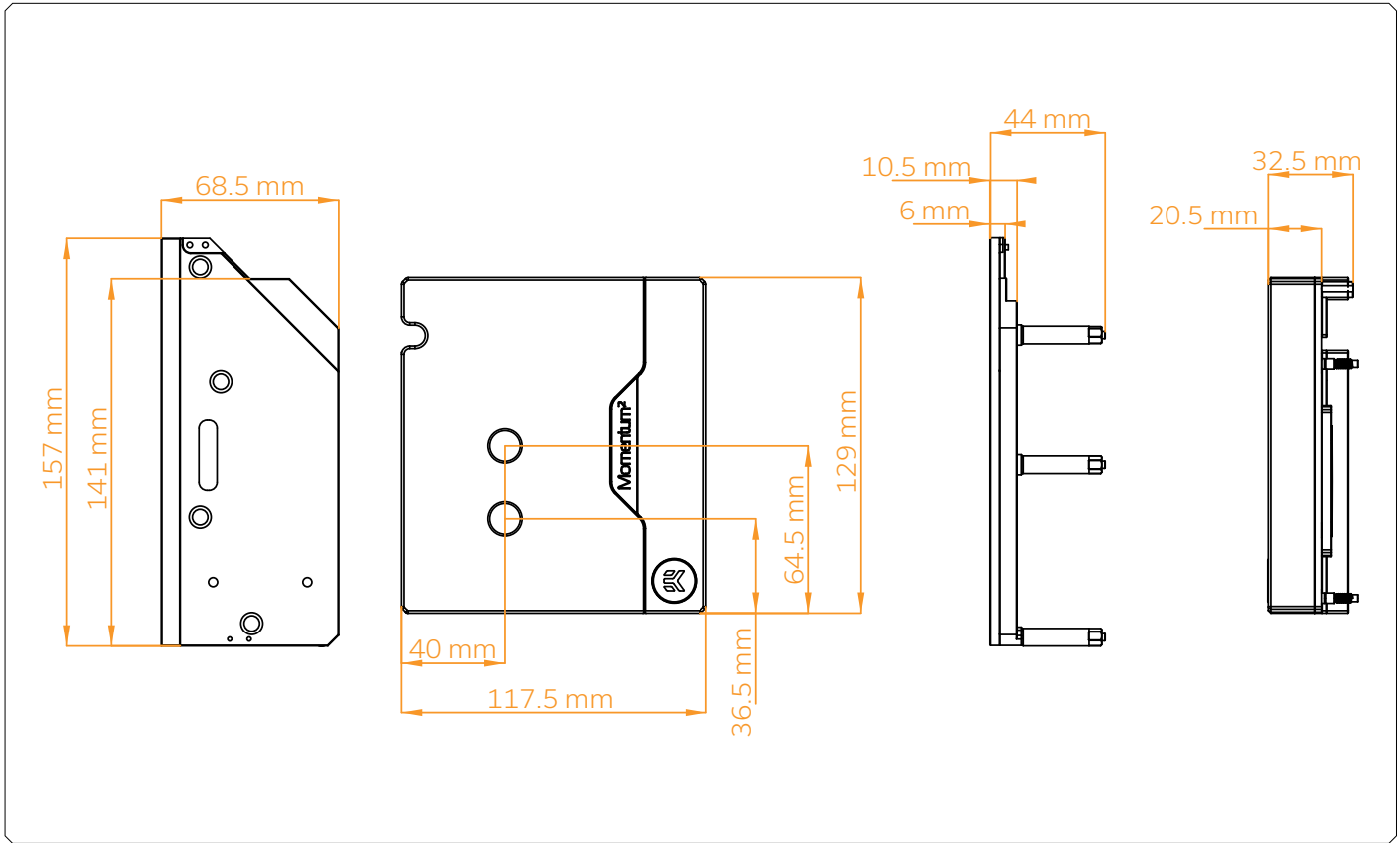

TECHNICAL SPECIFICATIONS AND WATER BLOCK PARTS

Technical Specification:

- Dimensions: (LxHxW) – 117.4 x 129 x 33 mm
- D-RGB cable length: 500 mm
- D-RGB connector standard 3-pin (+5V, Data, Blocked, Ground)

Position	EAN	Description	Quantity
1	106173	Mid-plate	1
2	105915	Coldplate (Ni)	1
3	106169	Mosfet N (Ni)	1
4	106171	Mosfet W (Ni)	1
5	106306	Stickout (Acetal)	1
6	106172	Top plate (Plexi)	1
7	8553	Standoff M4/M2.5 x 12.1 mm	2
8	106037	Velocity ² Mounting Screw AM5 (Ni)	4
9	8706	Spring M4 x 16 mm 8 kg	4
10	104774	OR 6 x 2 mm	1
11	105901	Kovina - Velocity ² Jet Plate - AM5	1
12	100663	EK - Badge	1
13	104773	OR 53 x 2 mm	1
14	104444	Mylar sticker	1
15	100500	Screw M4 x 12 DIN7991	4
16	8252	Screw M3 x 10 DIN7991	8
17	104771	Screw M3 x 20 DIN7991	4
18	106177	OR SET (1-5)	1
19	106178	OR SET (2-5)	1
20	106179	OR SET (3-5)	1
21	106180	OR SET (4-5)	1
22	106254	OR SET (5-5)	1
23	106176	I/O Replacement cover (Black e.)	1
24	105132	Standoff M4/M2 x 30.75 mm (Ni)	3
25	101946	LED D-RGB Strip - 500/200 mm	1

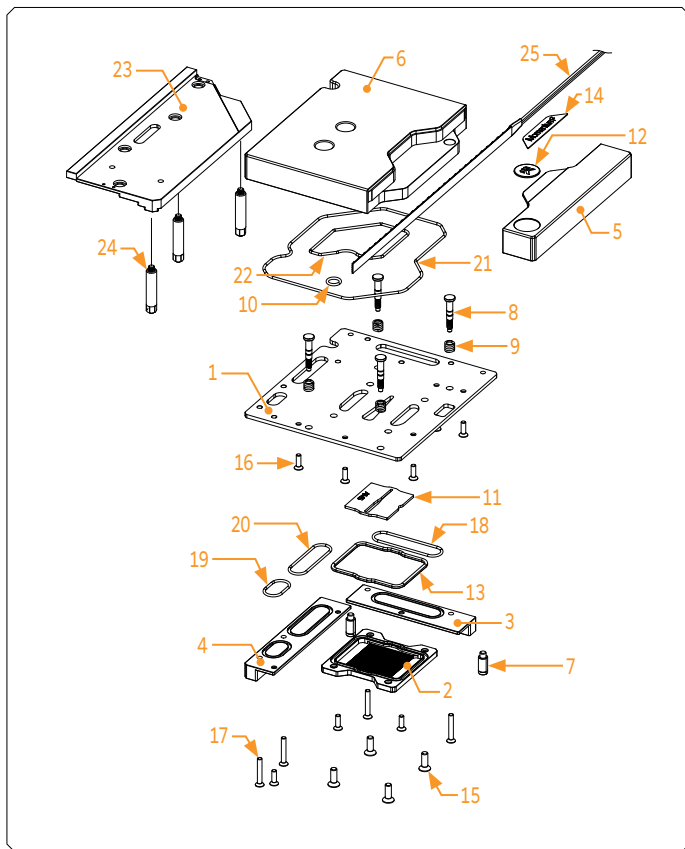

PREPARING THE MOTHERBOARD

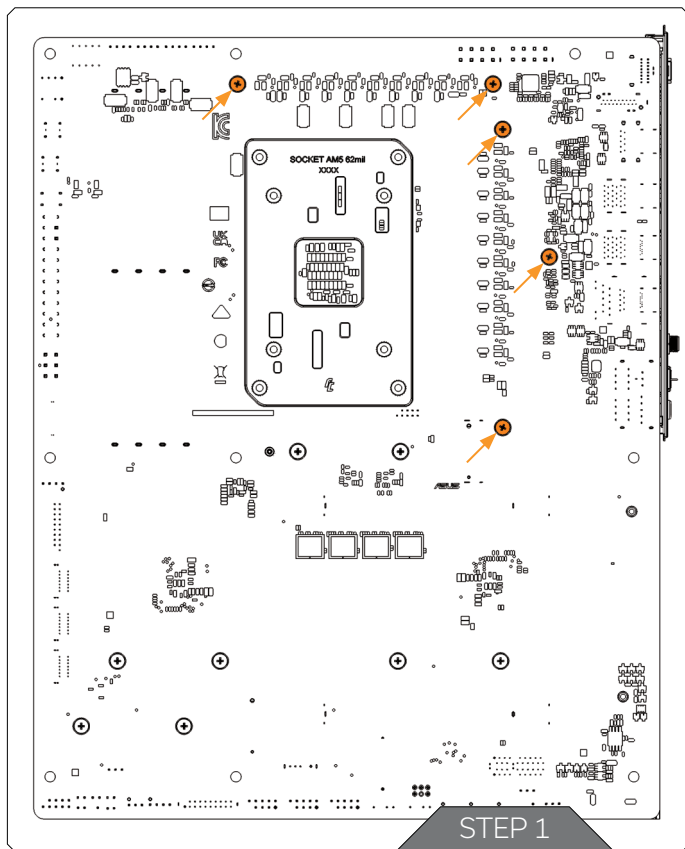

STEP 1 REMOVING THE STOCK COOLER



Important! Before starting, make sure to have a clean, flat surface to work on. It is recommended that you put a foam or a soft material to lay the motherboard and the water block on.

Using a Phillips-head screwdriver remove the five (5) factory screws from the motherboard's backside and detach the stock cooler. Save the stock cooler and screws for later steps.

For this step, you will need:

Phillips Head Screwdriver

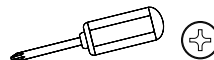

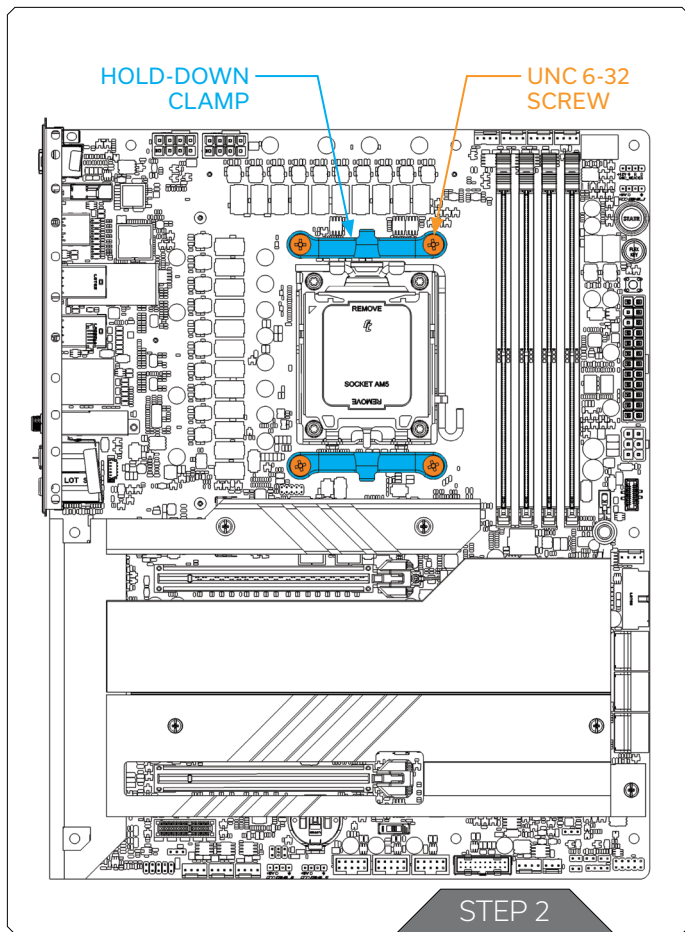

STEP 2

Using a Phillips-head screwdriver remove the four UNC 6-32 screws securing the original plastic hold-down clamps around the socket as shown in the illustration. Remove the hold-down clamps and store them away.

For this step, you will need:

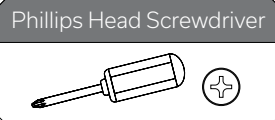

PREPARING THE REPLACEMENT COVER

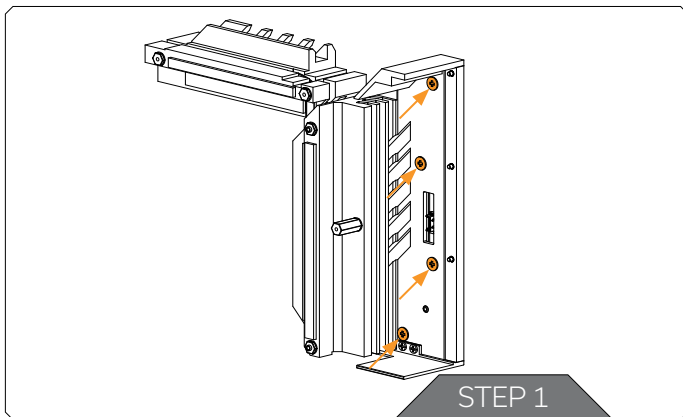

STEP 1

From the saved stock cooler, remove four (4) marked screws and detach the screen.

For this step, you will need:

Phillips Head Screwdriver

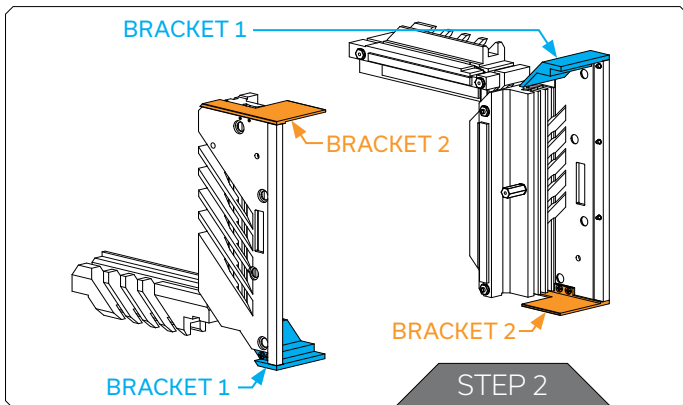
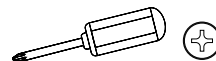

STEP 2

Additional two (2) brackets must be removed. Save the brackets and screws for the next step.

For this step, you will need:

Phillips Head Screwdriver

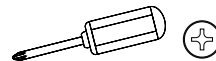

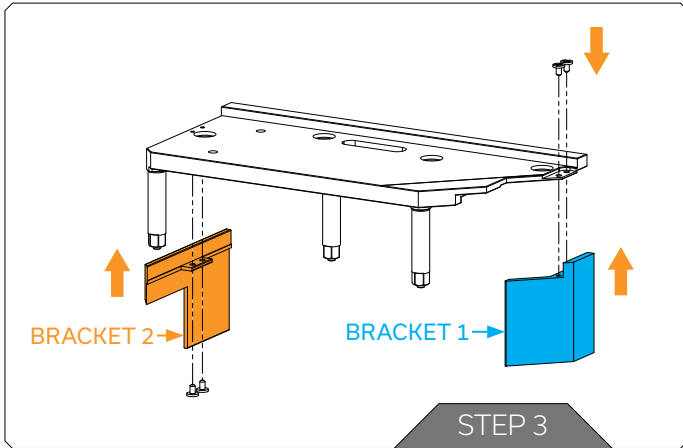

STEP 3

Take the replacement cover and reuse the stock brackets. Tighten the brackets using a Phillips head screwdriver. Make sure not to overtighten the screws.

For this step, you will need:

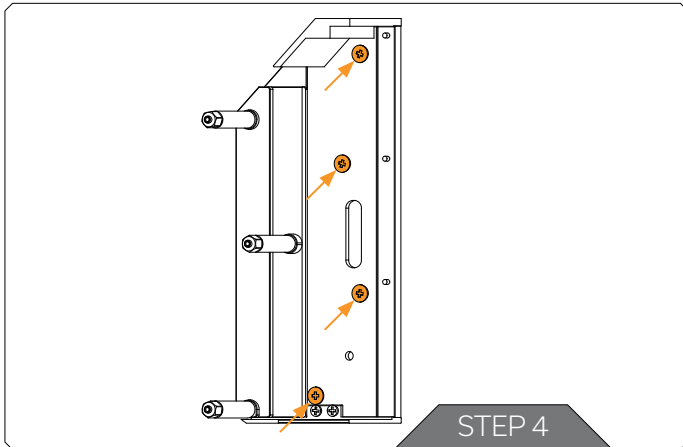
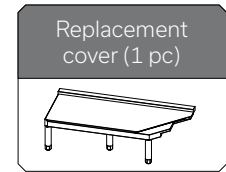
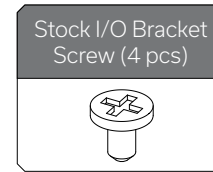
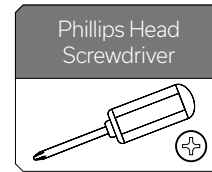

STEP 4

The I/O screen can be reused after securing the brackets. Tighten it with saved stock screws.

For this step, you will need:

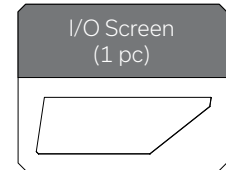
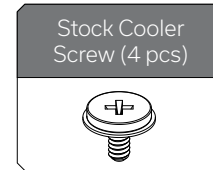
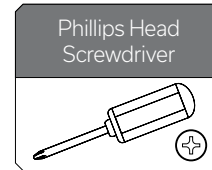

INSTALLING THE WATER BLOCK

Thermal Pad G - 0.5 mm (120 x 24 mm)



Thermal Pad G - 1.5 mm (120 x 24 mm)



G0.5 Thermal Pad - 120 x 24 x 0.5 mm

G1.5 Thermal Pad - 120 x 24 x 1.5 mm

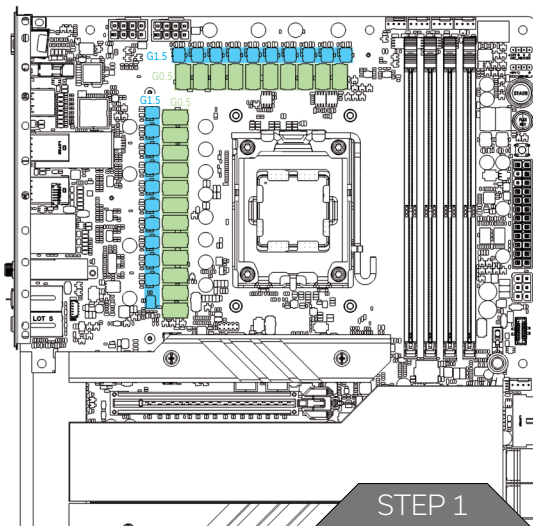

STEP 1

CUTTING AND PLACING THERMAL PADS

EK-Quantum Momentum² ROG Crosshair X670E Hero D-RGB water block comes with thermal pads that have to be cut into smaller pieces to cover all the regulation areas (Mosfet) on the water block. EK made sure to provide you with more than an adequate quantity of thermal pads to complete this Step.



Please remove the protective foil from both sides of the thermal pads prior to installation!

Replacement thermal pads:

Thermal Pad G 0.5 mm (120 x 24) EAN: 3830046996763

Thermal Pad G 1.5 mm (120 x 24) EAN: 3830046996787

For this step, you will need:

Scissors

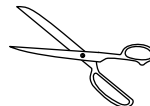

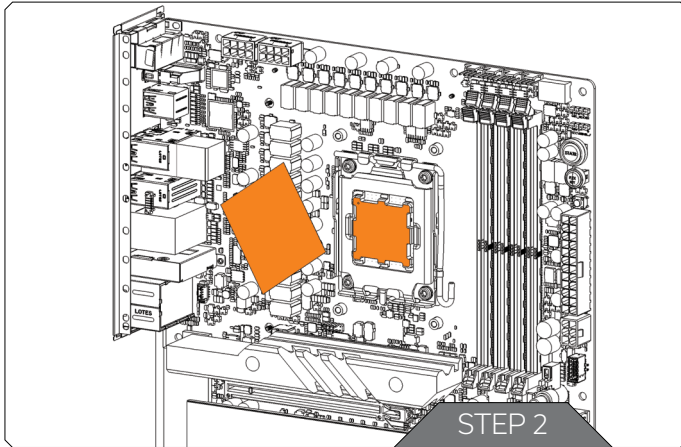

STEP 2

INSTALLING AND CLEANING THE CPU

Remove the CPU(IHS) protective plastic and place the CPU(IHS) in the socket. Wipe the IHS clean using a non-abrasive cloth or Q-tip as shown in the illustration.

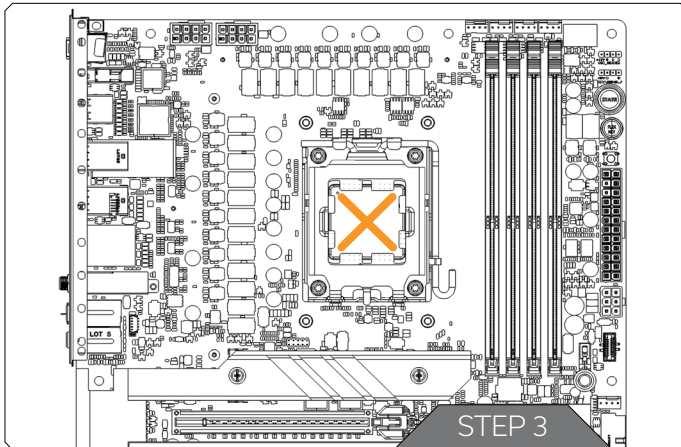

STEP 3

APPLYING THERMAL COMPOUND

Apply the enclosed thermal grease (thermal compound) on the CPU heat spreader – IHS – as shown in the image. The layer of the thermal compound must be thin and even in thickness over the entire surface of the IHS.

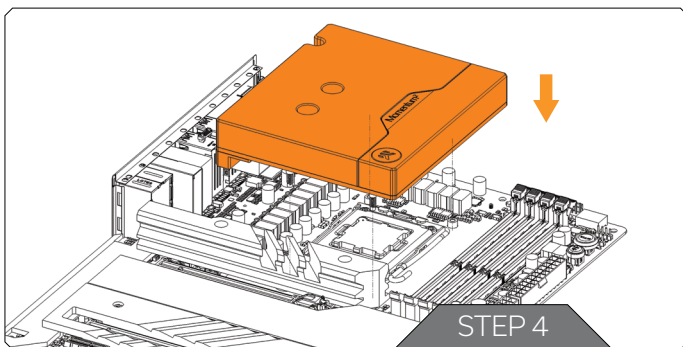

STEP 4

Carefully place the CPU water block onto the motherboard and align four(4) mounting screws with four (4) holes on the motherboard. Hold the water block and motherboard and turn them upside down.

STEP 5

Secure the water block from the backside of the motherboard using the included Tx7 L-Shaped wrench. Additional two (2) M2.5 x 5 AX1 screws and PVC washers must be used to tighten the water block (shown in the picture).

Using Tx7 L-Shaped wrench, tighten the mounting screws in an anti-clockwise direction.

Start fastening the screws in a cross pattern. Do not tighten fully until all of the screws are partially screwed in.

The Tx7 L-Shaped wrench must be used in a standing position! Otherwise, the mounting screws may crack during tightening!

For this step, you will need:

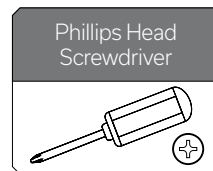

Phillips Head
Screwdriver

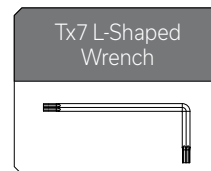

Tx7 L-Shaped
Wrench

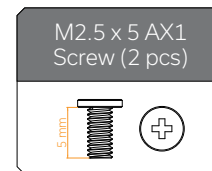

M2.5 x 5 AX1
Screw (2 pcs)

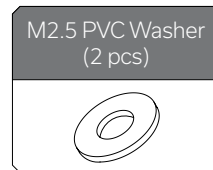

M2.5 PVC Washer
(2 pcs)

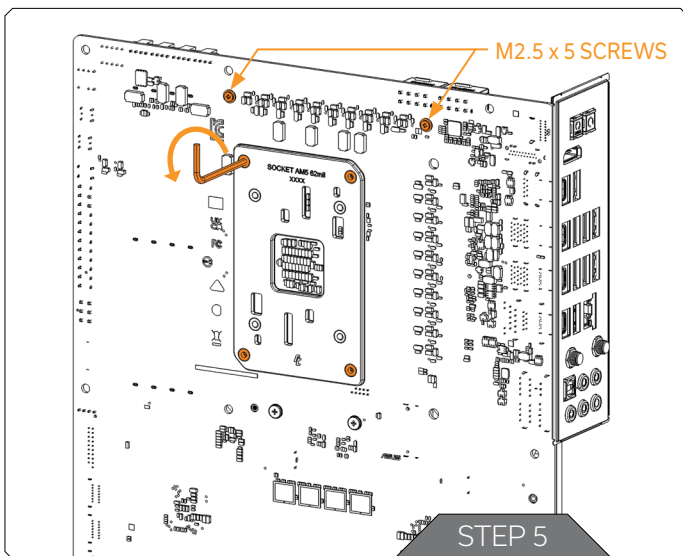

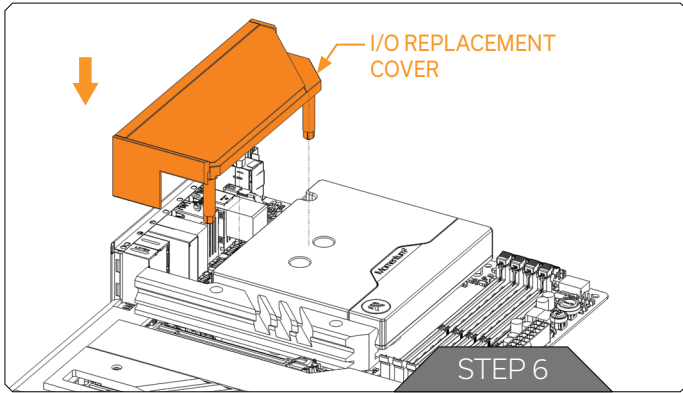

STEP 6

Carefully place the I/O replacement cover onto the motherboard and align three (3) mounting standoffs with three (3) holes on the motherboard.



Do not forget to plug in the screen cable before tightening the cover.

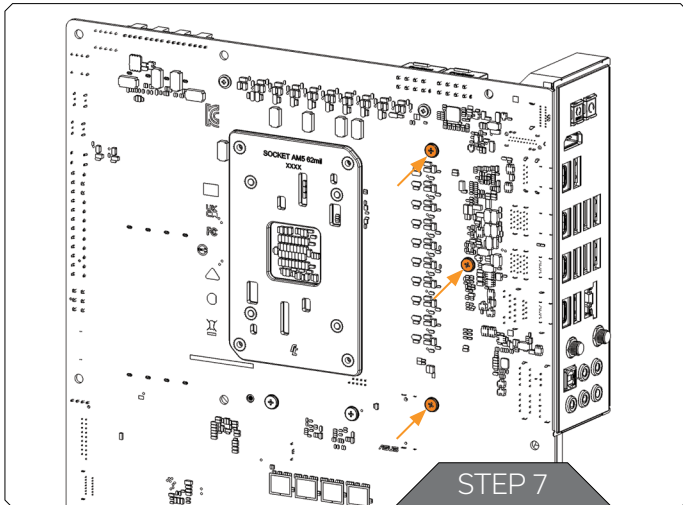

STEP 7

From the backside of the motherboard, secure the I/O Replacement cover using three (3) saved STOCK COOLER Screws. Make sure not to overtighten the screws.

For this step, you will need:

Phillips Head
Screwdriver

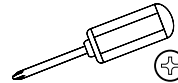

Stock Cooler
Screw (3 pcs)



FITTINGS AND TUBING

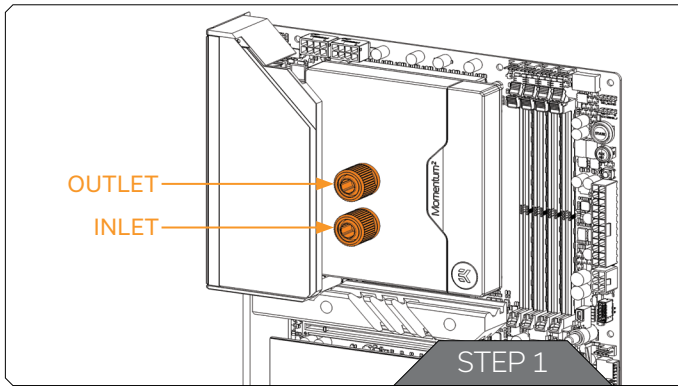

STEP 1

With EK-Momentum series water blocks, it is mandatory to use the bottom port as the INLET.

Mixing the ports may result in poor thermal performance of the water block.

Tighten the fittings in a clockwise direction until the gasket underneath is compressed. The installation of the Velocity² water block is now complete.

CONNECTING THE D-RGB LED STRIP

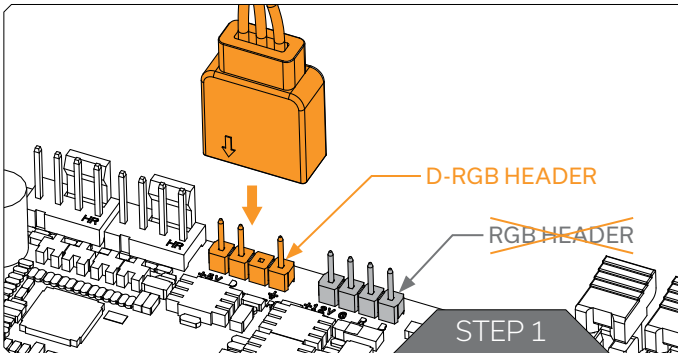

STEP 1

Plug the 3-Pin connector from the water block's D-RGB LED light to the DRGB HEADER on the motherboard. The LED will work if the pin layout on the header is as follows: **+5V, Digital, empty, Ground**.



Please ensure that the arrow indicated on the connector is plugged into the +5V line as indicated on your motherboard. If you put the LED Diode to the 12V RGB HEADER you can damage the LEDs. Failure to do so will damage your motherboard or LED strip.

TESTING THE LOOP

To make sure the installation of EK components was successful, we recommend you perform a leak test for 24 hours. When your loop is complete and filled with coolant, connect the pump to a PSU outside of your system. Do not connect power to any of the other components. Turn on the PSU and let the pump run continuously. It is normal for the coolant level to drop during this process as air collects in the distribution plate. Inspect all parts of the loop, and in the eventuality, that coolant leaks, fix the issue and repeat the testing process. Ensure that all hardware is dry before the system is powered on in order to prevent any damage.

WARRANTY

Our products are warranted against defects of materials and quality for a period of 24 months, starting with the date of delivery to the end-user. During this period, products will be repaired or have parts replaced at our discretion, provided that 1) the product is returned to the agent from whom it was purchased; 2) the product has been purchased by the end-user and has not been used for commercial purposes; 3) the product has not been misused, handled carelessly, or used in a manner other than the way described in the instructions manual. This warranty does not confer rights other than those expressly set out above and does not cover any claims for consequential loss or damage. This warranty is offered as an extra benefit and does not affect your statutory rights as a consumer. This warranty is voided if the product comes in contact with aggressive UV additives or other improper liquids. EK water blocks are sealed with a warranty-voiding circular label, proving the water block has withstood a pressure leak test. Removing the label will void the leak-free guarantee, but not the guarantee on the product itself. Any other RMA issues can be reported to EK Customer Support at www.ekwb.com/support for further analysis.

SUPPORT AND SERVICE

In case you need assistance or wish to order spare parts or a new mounting mechanism, please contact:

<https://www.ekwb.com/customer-support/>

For spare parts orders, refer to the page with "TECHNICAL SPECIFICATIONS AND WATER BLOCK PARTS" where you can find the EAN number of each part you might need.

Include the EAN number with quantity in your request. Mounting Mechanism EAN can be found under "BOX CONTENTS"

Thermal pads are readily available in the EK shop

SOCIAL MEDIA

 EKWaterBlocks

 @EKWaterBlocks

 ekwaterblocks

 EKWBofficial

 ekwaterblocks

