

EK-Quantum Vector² EVO Strix-TUF RTX 4080 ABP Set

GPU WATER BLOCK

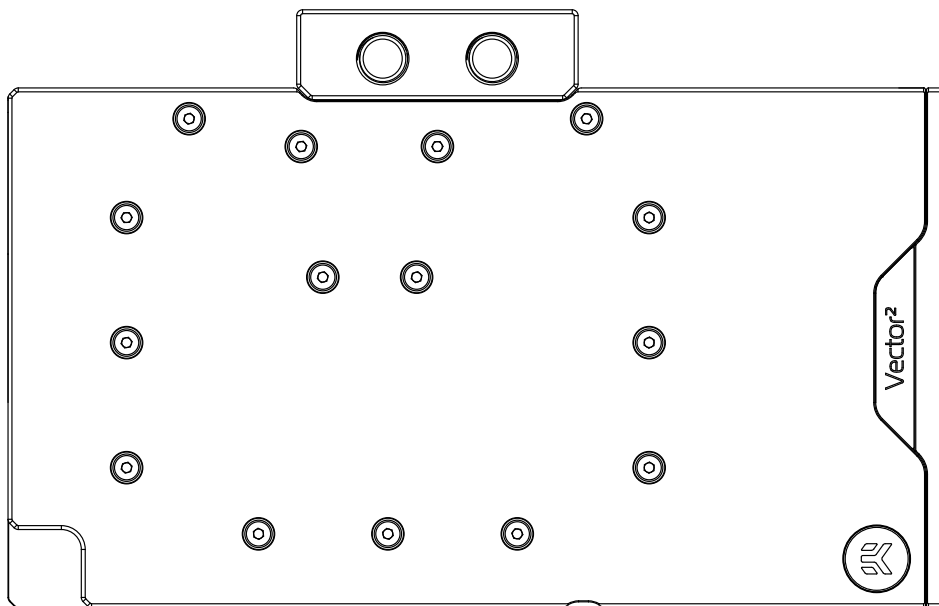

Please note the installation of the product is intended to be undertaken by an adequately trained and experienced person. You are installing the product at your own risk. If you are not properly trained or experienced or feel unsure about the installation procedure, please refrain from installing the product yourself and contact our tech support for assistance. We disclaim our liability for any damages to the product as well as incidental, consequential, or indirect damages incurred due to improper or inappropriate installation.

Before you start using this product, please follow these basic guidelines:

Carefully read the manual before beginning with the installation process.

Remove your graphics card from the computer for the safest mounting process to prevent any possible damage to your GPU or its circuit board (PCB).

The EK Fittings require only a small amount of force to screw them firmly in place since the liquid seal is ensured by the rubber O-ring gaskets.

The use of corrosion-inhibiting coolants is always recommended for liquid cooling systems and mandatory for nickel-plated water blocks!







Do not use pure distilled water!

For best results, EK recommends the use of EK-CryoFuel coolants! To reach optimal performance, make sure to thoroughly bleed the air out of your water block!

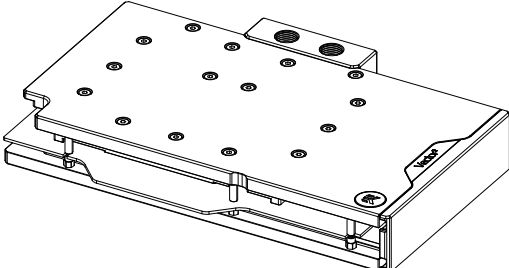
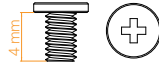
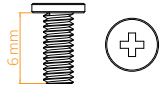
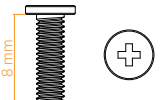
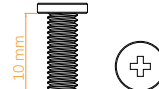
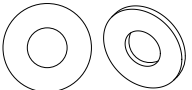
TABLE OF CONTENTS

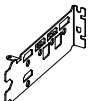
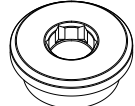
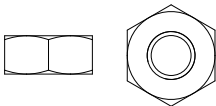
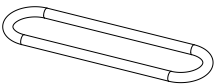
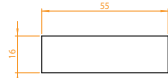
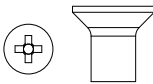
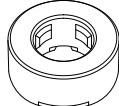
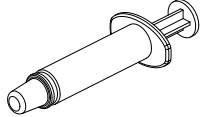
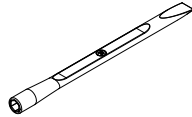
BOX CONTENTS	4
WATER BLOCK DIMENSIONS	5
TECHNICAL SPECIFICATIONS AND WATER BLOCK PARTS	6
NICKEL PLEXI	6
PREPARING THE GRAPHICS CARD	7
REMOVING THE STOCK COOLER	7
ASUS TUF-STRIX GEFORCE RTX 4080	7
PREPARING THE WATER BLOCK FOR INSTALLATION	9
CUTTING AND PLACING THERMAL PADS - WATER BLOCK	11
APPLYING THERMAL COMPOUND	13
ATTACHING THE WATER BLOCK	14
OPTION 1: USING ASUS GEFORCE RTX 4080 STRIX	14
OPTION 2: USING ASUS GEFORCE RTX 4080 TUF GAMING	15
CUTTING AND PLACING THERMAL PADS - BACKPLATE	17
ATTACHING THE ACTIVE BACKPLATE	19
INSERTING THE GRAPHICS CARD INTO THE CHASSIS	20
FITTINGS AND TUBING	20
CONNECTING THE D-RGB LED STRIP	21
TESTING THE LOOP	21
WARRANTY	22
SUPPORT AND SERVICE	23
SOCIAL MEDIA	23

BOX CONTENTS

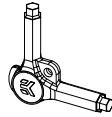
 <p>EK-Quantum Vector² EVO Strix/TUF RTX 4080 ABP D-RGB</p>		 <p>M2.5x4 AX1 Screw (12 pcs)</p>	 <p>M2.5x6 AX1 Screw (1 pc)</p>	 <p>M2.5x8 AX1 Screw (1 pc)</p>
		 <p>M3x10 AX1 Screw (1 pc)</p>	 <p>Polyamid Washer M2.5 0.5mm (12 pcs)</p>	 <p>Standoff M2.5-M3 x 6.6mm (1 pc)</p>
 <p>Thermal Pad - BP Chip - 30x30x1 (1 pc) (3831109914519)</p>	 <p>Replacement I/O Bracket (1 pc)</p>	 <p>EK - Plug G1/4 (2 pcs)</p>	 <p>Nut M2.5 (1 pcs)</p>	 <p>Terminal OR 14x1 mm (2 pcs)</p>
 <p>Thermal Pad - VRAM - 55x16x2 (6 pcs) (3831109914540)</p>	 <p>M3 x 6 DIN7991 Screw (2 pcs)</p>	 <p>Standoff Ø4.5/2.5 (2 pc)</p>	 <p>Thermal Grease (1 pc)</p>	 <p>EK-Plug Out Spludger Tool (1 pc)</p>
 <p>Thermal Pad - Inductor - 120x12x1 (2 pcs) (3831109914526)</p>	 <p>Thermal Pad - VRM - 120x6x2 (4 pcs) (3831109914533)</p>	 <p>Allen Key 2 mm (1 pc)</p>	 <p>Allen Key 2.5 mm (1 pc)</p>	 <p>EK-Loop Multi Allen Key (1 pc)</p>

EAN: 107479

WATER BLOCK DIMENSIONS

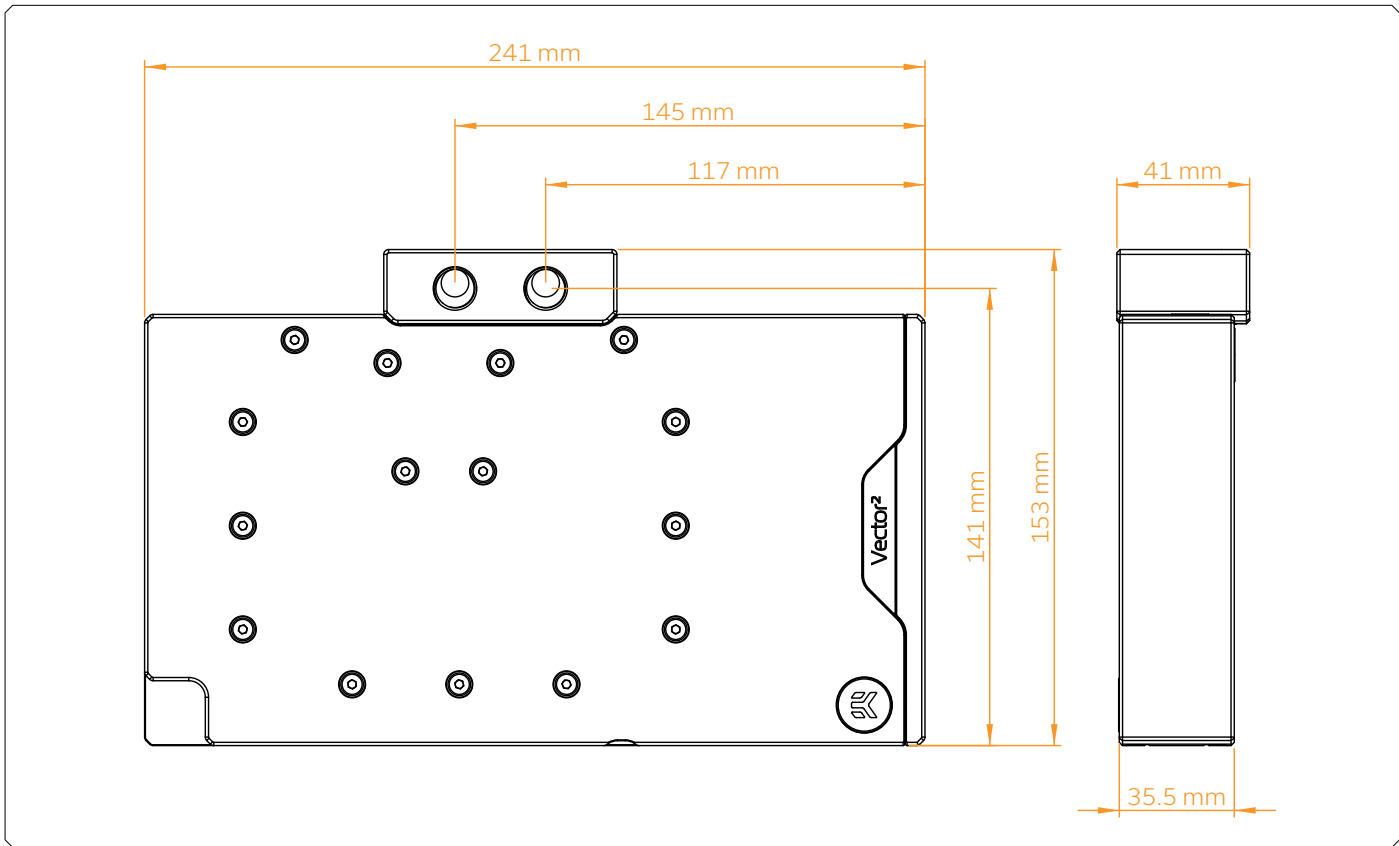

TECHNICAL SPECIFICATIONS AND WATER BLOCK PARTS

NICKEL PLEXI

- Dimensions: (L x H x W): 241 x 153 x 41 mm
- D-RGB LED count: 2 x 12
- D-RGB cable length: 50 cm
- D-RGB connector 3-pin 5V digital LED header

Position	EAN	Description	Quantity
1	8311	Screw M4 x 20 DIN7984	6
2	103942	Terminal Badge	1
3	104216	Disc magnet 3 x 3	4
4	104106	Terminal OR - 14 x 1 mm	4
5	106957	LED Cover (Nat. Elox)	2
6	8208	Screw M3 x 8 7991DIN	2
7	103964	Mylar sticker	2
8	101556	LED D-RGB strip	2
9	106969	Coldplate (Ni)	1
10	103988	Standoff M4-M2.5 x 3 mm	4
11	103987	Standoff M3.5-M2.5 x 3 mm	2
12	103986	Standoff M3.5-M2.5 x 11.3 mm	8
13	106133	Plexi insert	1
14	106975	Top Plate (Plexi)	1
15	9024	Screw M4 x 10 DIN7984	15
16	100663	EK Badge	2
17	106972	OR - Vector ² EVO Strix TUF RTX	1
18	105989	FC Terminal (Acetal)	1
19	8201	Screw M3 x 10 DIN7991	2
20	104414	OR 52 x 2 mm	1
21	104086	ABP Terminal Badge	1
22	105991	Direct Link Terminal Plate	1
23	106965	Sideplate	1
24	106980	Standout (Acetal)	1
25	106977	Top plate ABP (Plexi)	1
26	106971	Coldplate ABP (Nickel)	1
27	104093	Standoff M2.5-M3 x 6.6 mm	6
28	104105	Screw AX1 M3 x 10	6
29	106974	OR - ABP	1
30	9013	Screw M4 x 8 DIN7984	13
31	107524	PCB Cardboard	1

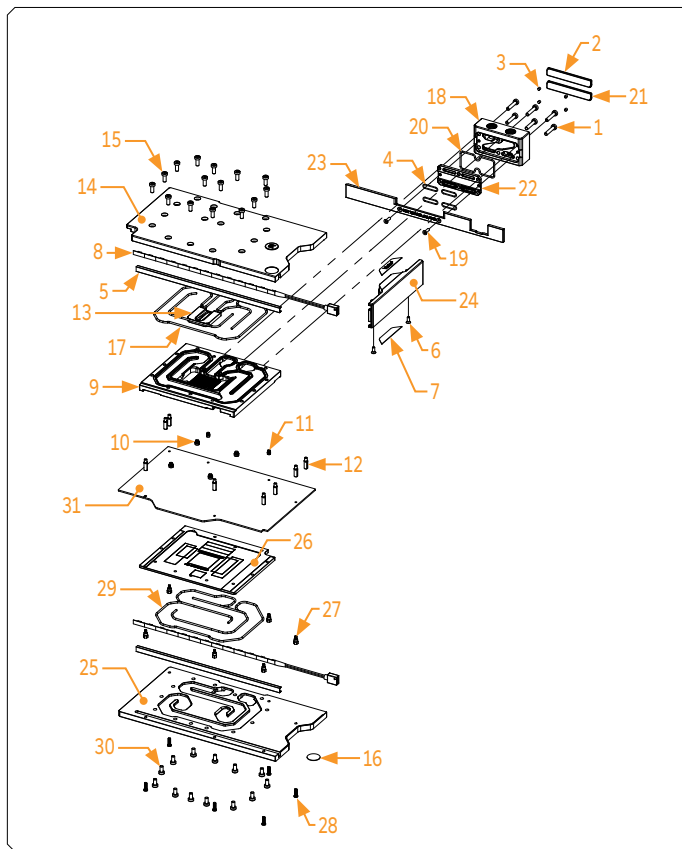

PREPARING THE GRAPHICS CARD

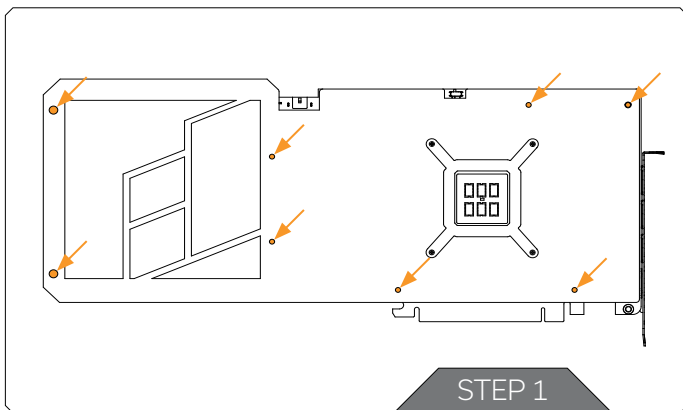

REMOVING THE STOCK COOLER

ASUS TUF-STRIX GEFORCE RTX 4080



Important! Before starting, make sure to have a clean, flat surface to work on. It is recommended to put foam or soft material to lay the graphics card on.

STEP 1

First, remove eight (8) screws from the backside of the Stock cooler (using Phillips head screwdriver).

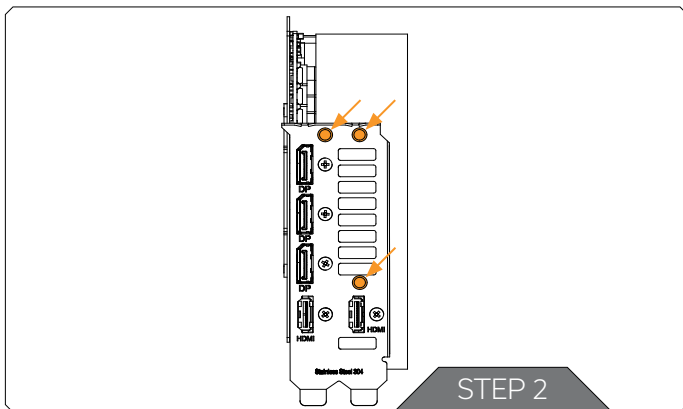

STEP 2

Unscrew three (3) screws from the I/O Bracket (using Phillips head screwdriver). Unplug the connectors in order to remove the stock cover from the GPU PCB.

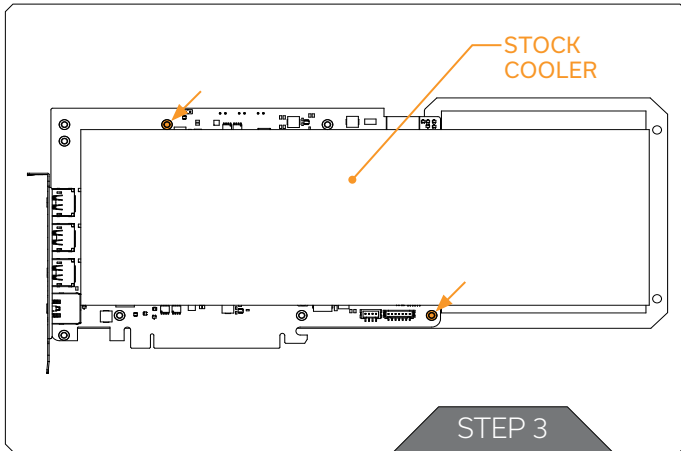

STEP 3

From the front side of the GPU, an additional two (2) screws must be removed (using Phillips head screwdriver). Detach the GPU Backplate.

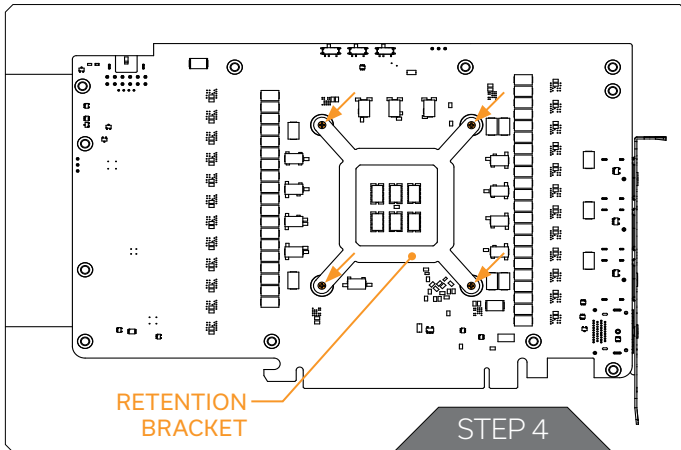

STEP 4

Rotate the GPU and unscrew four (4) Screws from the retention bracket (using Phillips head screwdriver). Remove the bracket and Stock Cooler from the GPU PCB.

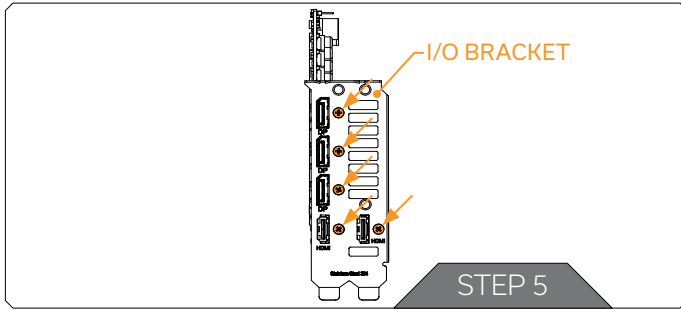

STEP 5

Lastly, unscrew five (5) Screws and detach the I/O Bracket (using Phillips head screwdriver).

EK provides the replacement I/O Bracket with the water block.

PREPARING THE WATER BLOCK FOR INSTALLATION

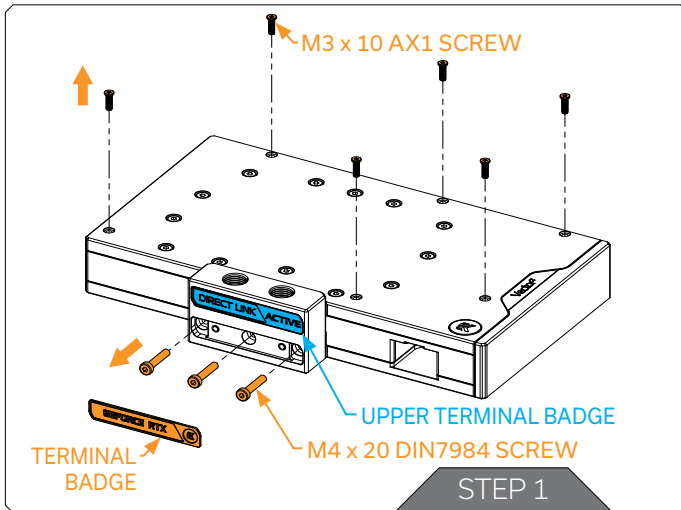

STEP 1

First, remove the terminal badge which is attached to the terminal with two magnets. Under the badge, unscrew three (3) screws M4 x 20 DIN7984. An additional six (6) screws M3 x 10 AX1 need to be removed (as shown in the image). Save the removed parts for later use.



DO NOT REMOVE THE UPPER TERMINAL BADGE!

For this step, you will need:

Phillips Head Screwdriver

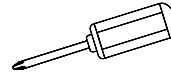

Allen Key 2.5mm



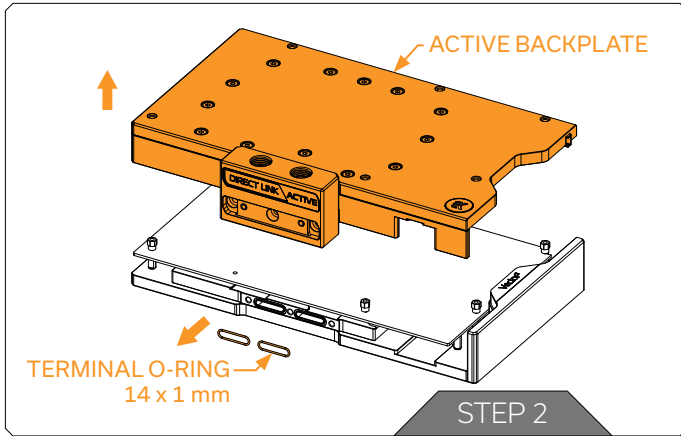

STEP 2

Carefully remove the complete active backplate with the terminal. Additional two (2) O-rings 14 x 1 EPDM50 needs to be removed.

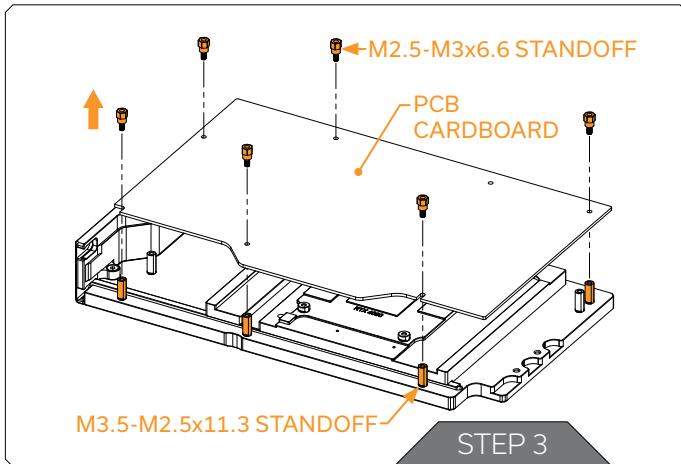

STEP 3

Unscrew six (6) M2.5-M3 x 6.6 standoffs with the provided tool (EK-Plug out Spludger Tool). Make sure not to unscrew the M3.5-M2.5 x 11.3 standoff! In case the M3.5-M2.5 x 11.3 standoff unscrews, carefully tighten it back with the 4 mm wrench. After removing the standoffs, the PCB cardboard needs to be removed. Save the removed parts for later use.

For this step, you will need:

EK-Plug Out Spludger Tool

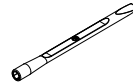

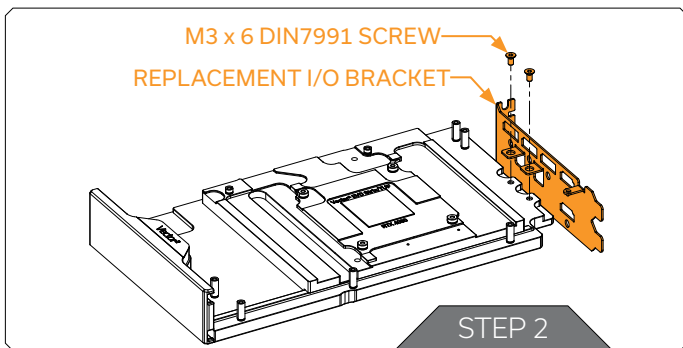

STEP 4

Position the replacement I/O Bracket on the water block. During this process, make sure you have aligned the holes. Secure it with the two (2) M3 x 6 DIN7991 Screws and Allen Key 2 mm.

For this step, you will need:

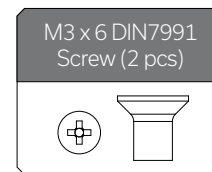
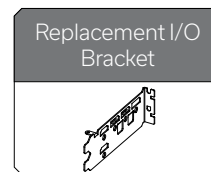
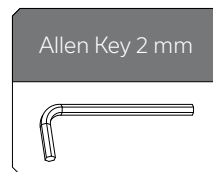

CUTTING AND PLACING THERMAL PADS - WATER BLOCK

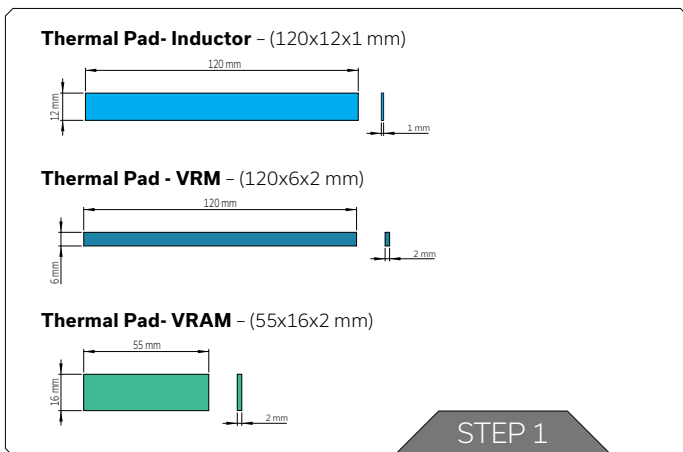

STEP 1

The GPU water block comes with pre-cut thermal pads, but some of them need to be additionally cut into smaller pieces.

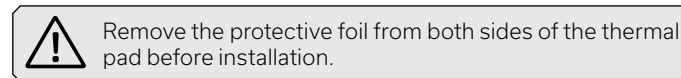

Replacement thermal pads:

Thermal Pad- Inductor - (120x12x1 mm) EAN: 3831109914526 - 2 pcs

Thermal Pad- VRM - (120x6x2 mm) EAN: 3831109914533 - 2 pcs

Thermal Pad- VRAM - (55x16x2 mm) EAN: 3831109914540 - 3 pcs

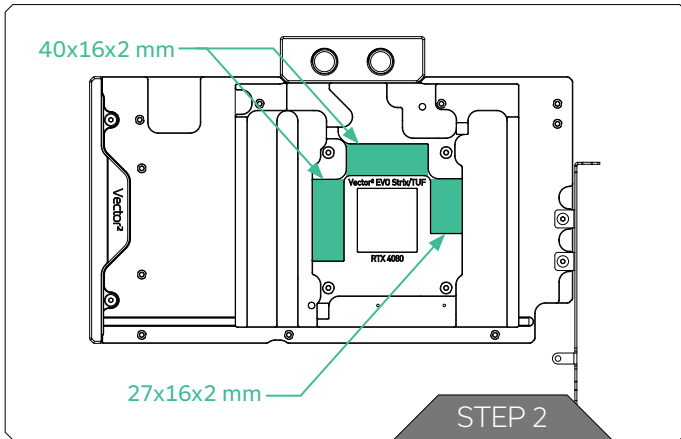

STEP 2

Use three (3) Thermal Pads- VRAM – (55x16x2 mm).
 Take two (2) pcs and cut them to the length of 40 mm.
 Take one (1) pc and cut it to the length of 27 mm.

Thermal Pad- VRAM – (55x16x2 mm)

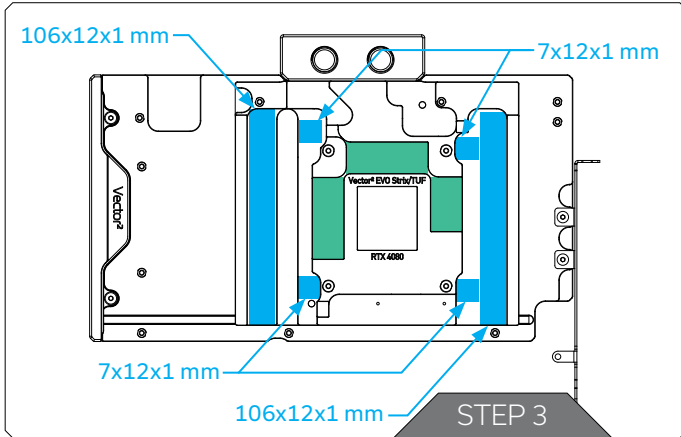
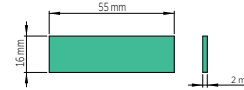

STEP 3

Use two (2) Thermal Pads- Inductor – (120x12x1 mm)
 From each of them cut two (2) pieces of length 7 mm.

Thermal Pad- Inductor – (120x12x1 mm)

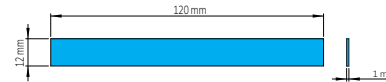

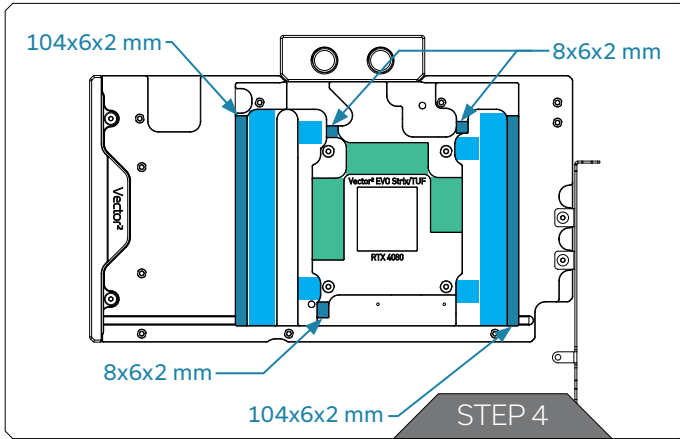

STEP 4

Use two (2) Thermal Pad - VRM - (120x6x2 mm)
From each of them cut two (2) pieces of length 8 mm.

Thermal Pad - VRM - (120x6x2 mm)

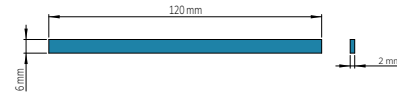

APPLYING THERMAL COMPOUND

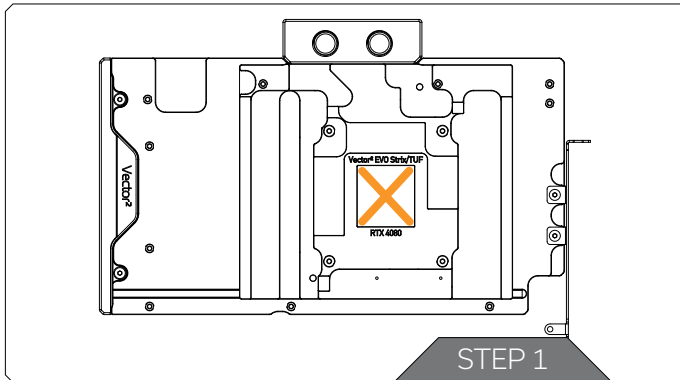

STEP 1

Apply the enclosed thermal grease (thermal compound) on the GPU heat spreader - IHS - as shown in the image. The layer of the thermal compound must be thin and even over the entire surface of the IHS.

 The excessive or uneven application of thermal grease may lead to poor performance!

For this step, you will need:

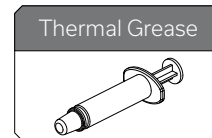

ATTACHING THE WATER BLOCK

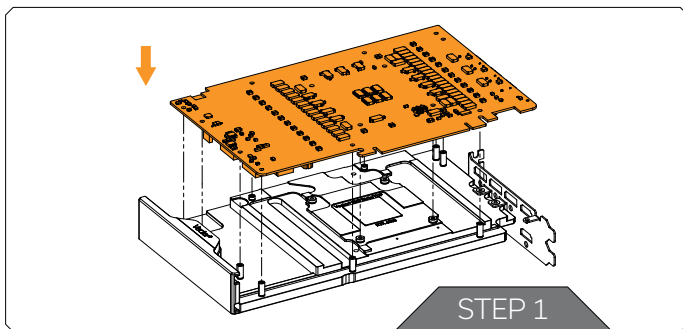

STEP 1

Carefully position the PCB on the water block. During this process, make sure you have aligned the mounting holes of the PCB with the holes of the water block.



Pay attention not to use too much force when pressing the PCB down to the block since chip dies are prone to cracking.



Before attaching the PCB to the Water Block, make sure all the Thermal Pads are placed correctly!

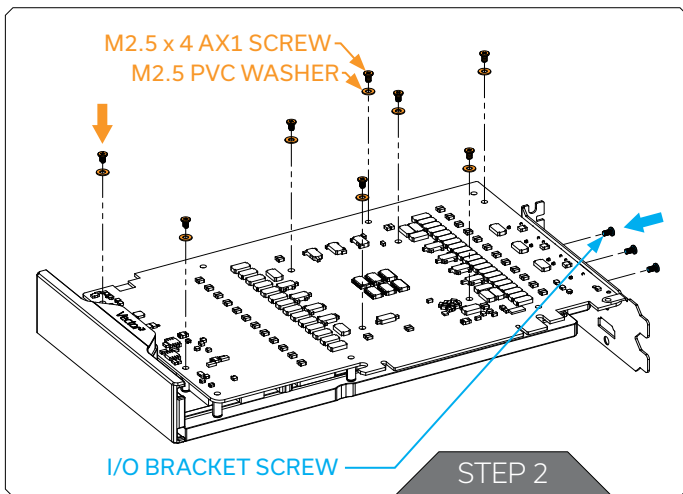

STEP 2

OPTION 1: USING ASUS GEFORCE RTX 4080 STRIX

Use eight (8) M2.5 x 4 AX1 screws and PVC washers to tighten the GPU PCB. Tighten the screws evenly using the Phillips-head screwdriver. EK recommends you start tightening the screws around the GPU core first and then continuing outward to prevent damaging the GPU. Always use a plastic washer under each screw.

After attaching the water block, three (3) saved Factory provided I/O Bracket screws can be reused.

Phillips Head
Screwdriver

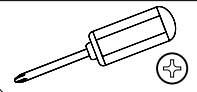

Screws must be present in the places marked on the picture.

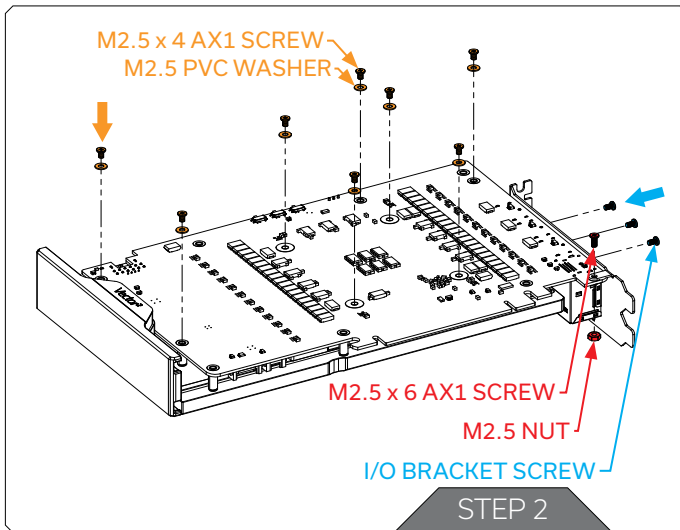
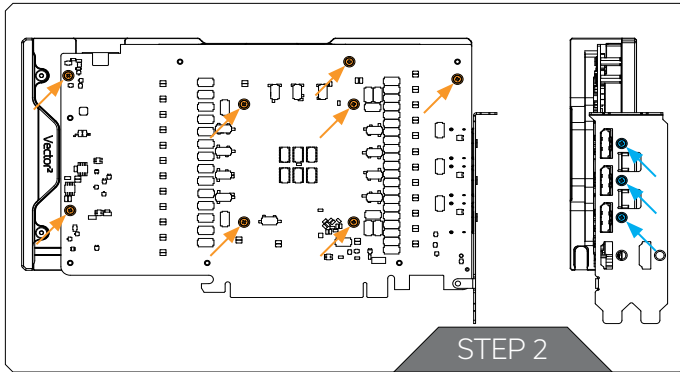

STEP 2

OPTION 2: USING ASUS GEFORCE RTX 4080 TUF GAMING

Use eight (8) M2.5 x 4 AX1 screws and PVC washers to tighten the GPU PCB. An additional one (1) M2.5 x 6 AX1 Screw must be secured with an M2.5 Nut. Tighten the screws evenly using the Phillips-head screwdriver. EK recommends you start tightening the screws around the GPU core first and then continuing outward to prevent damaging the GPU. Always use a plastic washer under each screw.

After attaching the water block, three (3) saved Factory provided I/O Bracket screws can be reused.

Screws must be present in the places marked on the picture.

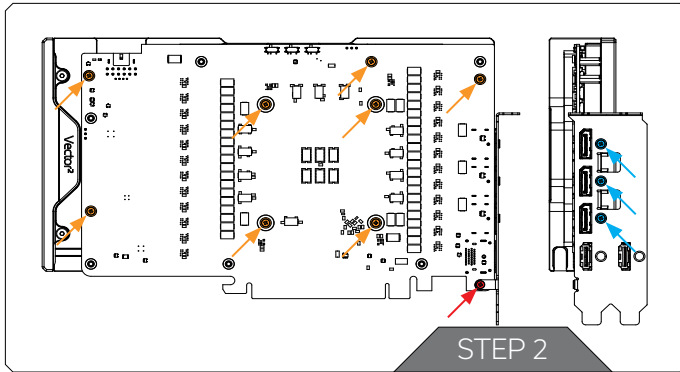

STEP 3

After securing the GPU PCB, position the five (6) M2.5-M3 x 6.6 standoffs. Tighten it with the provided tool (EK-Plug out Spludger Tool).

For this step, you will need:

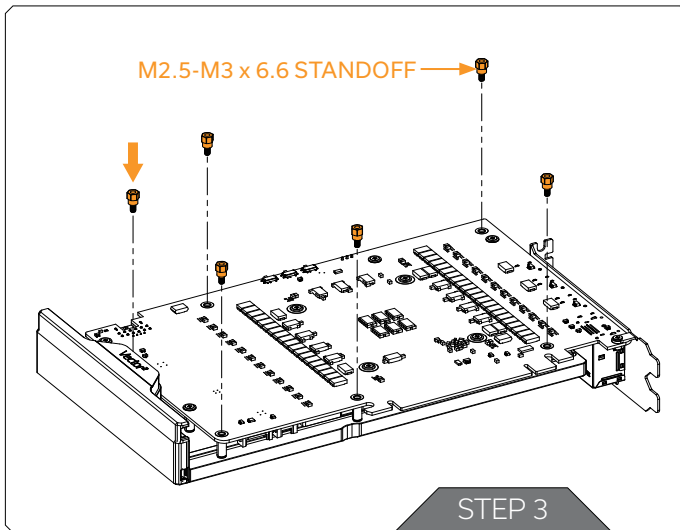
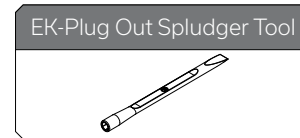

CUTTING AND PLACING THERMAL PADS - BACKPLATE

Thermal Pad - VRM - (120x6x2 mm)

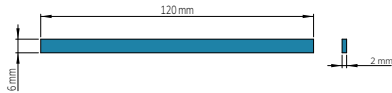

Thermal Pad - VRAM - (55x16x2 mm)

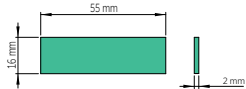

Thermal Pad - BP Chip - 30x30x1 mm

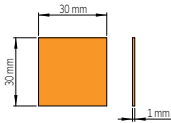

STEP 1

STEP 1

After attaching the water block, a few more thermal pads need to be placed on backplate to cover all the necessary components.



Pay attention not to use too much force when pressing the block down to the PCB since chip dies are prone to cracking.



Before attaching the PCB to the Water Block, make sure all the Thermal Pads are placed correctly!

Replacement thermal pads:

Thermal Pad- VRM - (120x6x2 mm) EAN: 3831109914533 - 2 pcs

Thermal Pad- VRAM - (55x16x2 mm) EAN: 3831109914540 - 3 pcs

Thermal Pad - BP Chip - 30x30x1 mm EAN: 3831109914519 - 1 pc

STEP 2

Place Thermal Pad - BP Chip - 30x30x1 mm on the marked position.

Thermal Pad - BP Chip - 30x30x1 mm

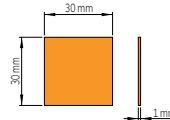

30x60x1 mm

STEP 2

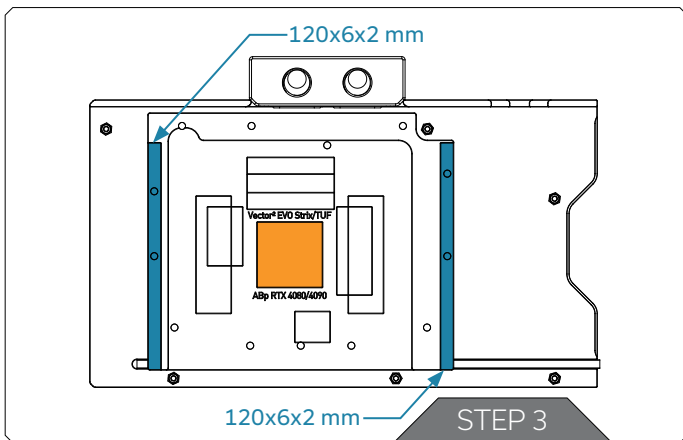

STEP 3

Place Thermal Pad- VRM - (120x6x2 mm) on the marked position.

Thermal Pad - VRM - (120x6x2 mm)

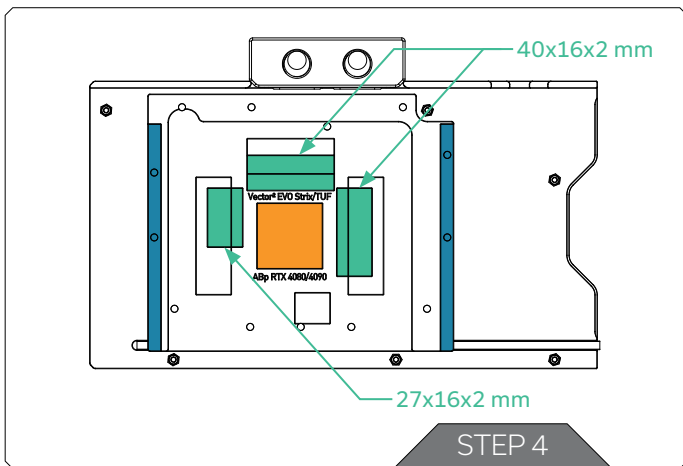
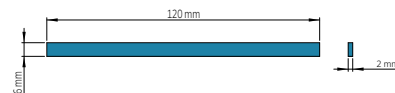

STEP 4

Use three (3) Thermal Pads- VRAM - (55x16x2 mm).
Take two (2) pcs and cut them to the length of 40 mm.
Take one (1) pc and cut it to the length of 27 mm.

Thermal Pad- VRAM - (55x16x2 mm)

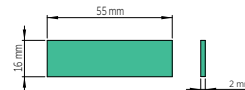

ATTACHING THE ACTIVE BACKPLATE

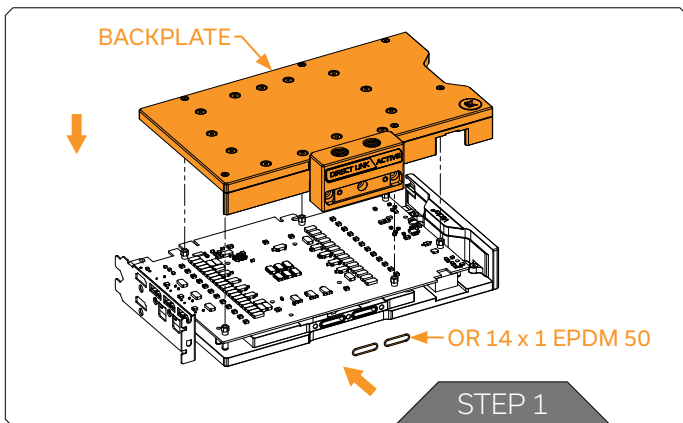

STEP 1

Insert two (2) O-rings (14 x 1 mm) into slots on the cold plate. Then carefully place the active backplate on standoffs (as shown in the image). While putting the active backplate on the PCB, make sure the O-rings stay in the slots.



Before attaching the Active Backplate, make sure all the Thermal Pads are placed correctly!

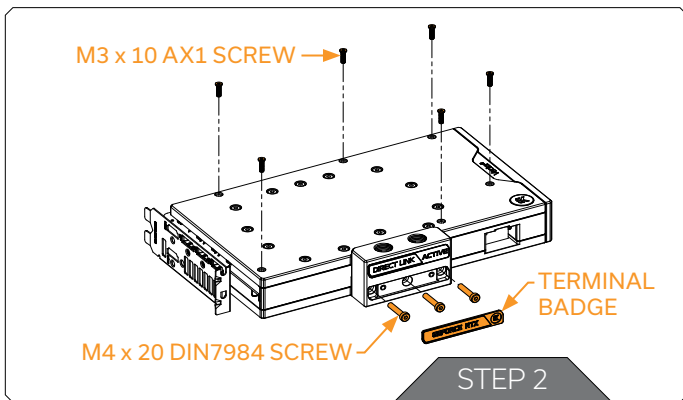

STEP 2

Place five (5) M3 x 10 AX1 screws into the water block standoffs and tighten them using a Phillips head screwdriver (as shown in the image). After attaching the AX1 Screws, three (3) terminal screws M4 x 20 DIN7984 need to be attached using Allen Key 2.5 mm. The terminal badge can be reused, after securing the terminal screws.

For this step, you will need:

Phillips Head Screwdriver

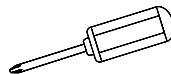

Allen Key 2.5mm



INSERTING THE GRAPHICS CARD INTO THE CHASSIS

Carefully lift your graphics card with the installed water block and insert it into your PC's motherboard PCI Express expansion slot. Please keep in mind that your graphics card is heavier than before it was equipped with the water block.



You need to be very careful when handling the graphics card. Avoid all unnecessary manipulation of the water block assembly that might damage your card or water block.

FITTINGS AND TUBING

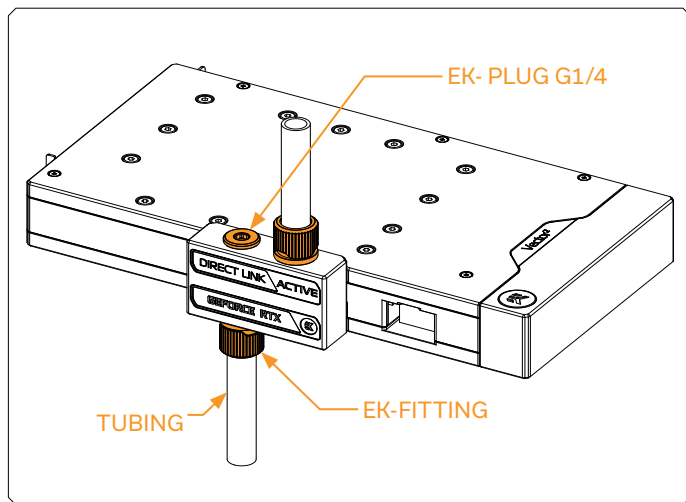

Screw in two (2) G1/4 threaded male fittings. Attach the liquid cooling tubes and connect the water block to the cooling loop.



Do not forget to plug the remaining two openings using the enclosed EK-Plug G1/4 or its equivalent.

EK recommends using EK fittings with all EK water blocks.



CAUTION: When using connectors other than EK fittings, pay special attention to the length of the fittings' male G1/4" thread - 5mm is the maximum G1/4" thread length allowed!

For this step, you will need:

EK-Loop Multi Allen Key



CONNECTING THE D-RGB LED STRIP

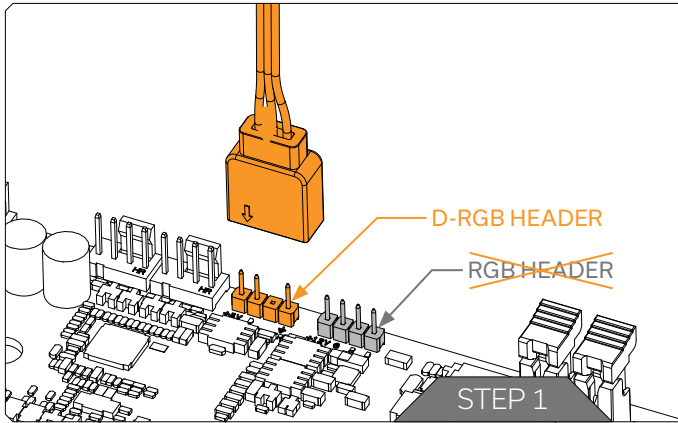

STEP 1

Plug the **3-pin connector** of the distribution plate D-RGB LED light to the **D-RGB HEADER** on the motherboard. The LED will work if the pin layout on the header is as follows: **+5V, Digital, Empty, Ground**.



Incorrect installation or installation to a wrong header can damage the LED strip or the header itself!

TESTING THE LOOP

To make sure the installation of EK components was successful, we recommend you perform a leak test for 24 hours. When your loop is complete and filled with coolant, connect the pump to a PSU outside of your system. Do not connect power to any of the other components. Turn on the PSU and let the pump run continuously. It is normal for the coolant level to drop during this process as air collects in the distribution plate. Inspect all parts of the loop, and in the eventuality, that the coolant leaks, fix the issue and repeat the testing process. Ensure that all hardware is dry before the system is powered on in order to prevent any damage.

WARRANTY

Our products are warranted against defects of materials and quality for a period of 24 months, starting with the date of delivery to the end-user. During this period, products will be repaired or have parts replaced at our discretion, provided that 1) the product is returned to the agent from whom it was purchased; 2) the product has been purchased by the end-user and has not been used for commercial purposes; 3) the product has not been misused, handled carelessly, or used in a manner other than the way described in the instruction's manual. This warranty does not confer rights other than those expressly set out above and does not cover any claims for consequential loss or damage. This warranty is offered as an extra benefit and does not affect your statutory rights as a consumer. This warranty is voided if the product comes in contact with aggressive UV additives or other improper liquids. EK Water blocks are sealed with a warranty-voiding circular label, proving the water block has withstood a pressure leak test. Removing the label will void the leak-free guarantee, but not the guarantee on the product itself. Any other RMA issues can be reported to EK Customer Support at www.ekwb.com/support for further analysis.

SUPPORT AND SERVICE

In case you need assistance or wish to order spare parts or a new mounting mechanism, please contact:

<https://www.ekwb.com/customer-support/>

For spare parts orders, refer to the page with "TECHNICAL SPECIFICATIONS AND WATER BLOCK PARTS" where you can find the EAN number of each part you might need.

Include the EAN number with quantity in your request. Mounting Mechanism EAN can be found under "BOX CONTENTS"

Thermal pads are readily available in the EK shop

SOCIAL MEDIA

 EKWaterBlocks

 @EKWaterBlocks

 ekwaterblocks

 EKWBofficial

 ekwaterblocks

