

MSI MPG X570S Carbon EK X

MONOBLOCK

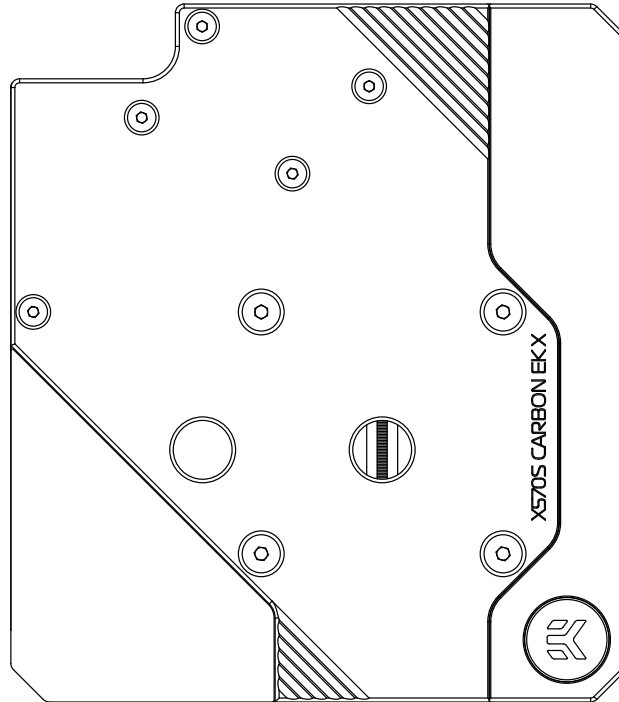

This product is intended for installation only by expert users. Please consult with a qualified technician for installation. Improper installation may result in damage to your equipment. EK Water Blocks assumes no liability whatsoever, expressed or implied, for the use of these products, nor their installation. The following instructions are subject to change without notice. Please visit our web site at www.ekwb.com for updates. Before installation of this product please read important notice, disclosure and warranty conditions printed on the back of the box.

Before you start using this product please follow these basic guidelines:

Please carefully read the manual thoroughly before beginning with the installation process!

Please remove your motherboard from the computer to assure safest mounting process in order to prevent any possible damages to your CPU and/or motherboard's circuit board (PCB).

The EK- Fittings require only a small amount of force to screw them firmly in place since the liquid seal is ensured by the rubber o-ring gaskets.

The use of quality, market proved corrosion inhibiting coolants is always strongly recommended for any liquid cooling system.

TABLE OF CONTENT

BOX CONTENTS	4
PREPARING YOUR MOTHERBOARD	5
REMOVING FACTORY PROVIDED BACKPLATE	5
REMOVING STOCK COOLER	5
REMOVING OF THE ORIGINAL PLASTIC HOLD-DOWN AND THE FACTORY BACKPLATE	6
APPLYING THERMAL COMPOUND	7
CUTTING THERMAL PADS	7
PLACING THERMAL PADS ON THE MOTHERBOARD	7
PLACING THE BLOCK ON TO MOTHERBOARD	8
ATTACHING BLOCK ON THE MOTHERBOARD	9
CONNECTING THE D-RGB LED STRIP	10
REQUIRED TOOLS	10
SUPPORT AND SERVICE	11
SOCIAL MEDIA	11

BOX CONTENTS

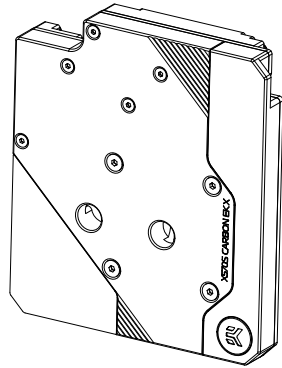

MSI MPG X570S Carbon EK X

Universal Mounting Mechanism – You may not need every screw from this package.

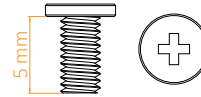

M2.5 x 5 AX1 Screw (5 pcs)

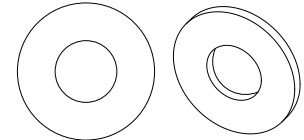

M2.5 PVC Washer (5 pcs)



Allen Key 2mm (1 pc)

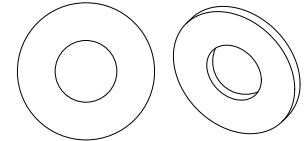

M2.5 Adhesive Washer (5 pcs)

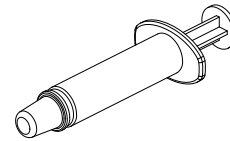

Thermal Grease (1 pc)

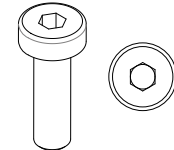

M3 x 10 DIN7984 (5 pcs)

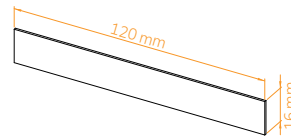

Thermal PAD F 1.0 mm - (120x16mm) (2 pcs)

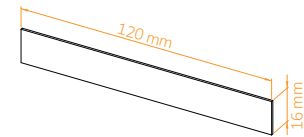

Thermal PAD F 1.5 mm - (120x16mm) (2 pcs)

PREPARING YOUR MOTHERBOARD

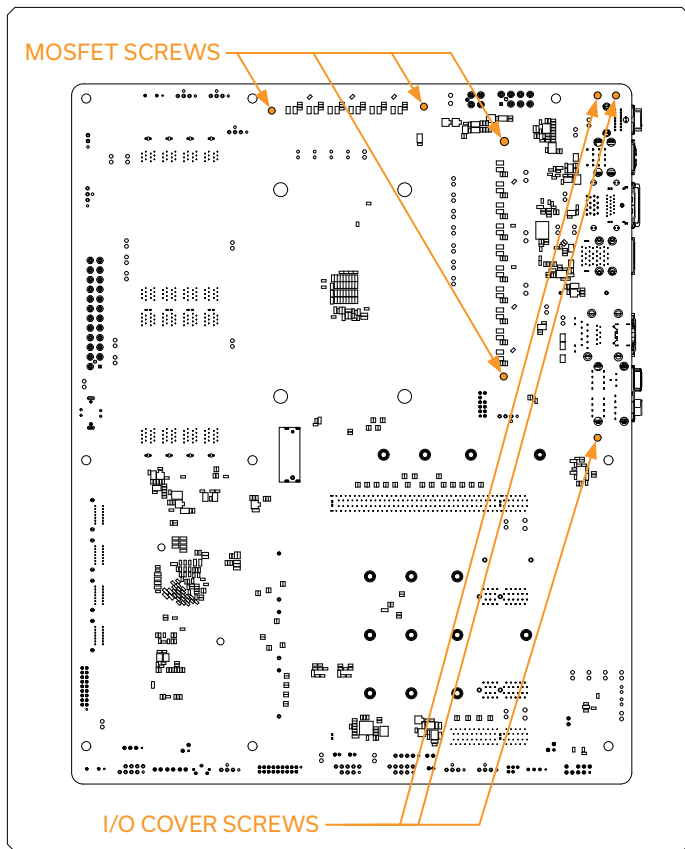

REMOVING FACTORY PROVIDED BACKPLATE

From the back side of the motherboard, remove five (5) screws using Phillips head screwdriver.

After removing the mention screws also remove two (2) remaining screws from the front side of the motherboard using Phillips head screwdriver and take off the factory provided backplate.

REMOVING STOCK COOLER

Remove all encircled screws. There are four (4) MOSFET screws on the back of the motherboard that needs to be removed. Additional three (3) screws needs to be removed to remove the plastic I/O cover. Store the screws for later use. You can attach the I/O cover back, after you mount the Monoblock.

REMOVING OF THE ORIGINAL PLASTIC HOLD-DOWN AND THE FACTORY BACKPLATE

Using Philips-head screwdriver remove the four (4) UNC 6-32 screws securing the original plastic hold-down clamps around the socket as shown on the sketch. Remove the original backplate and the hold-down clamps.

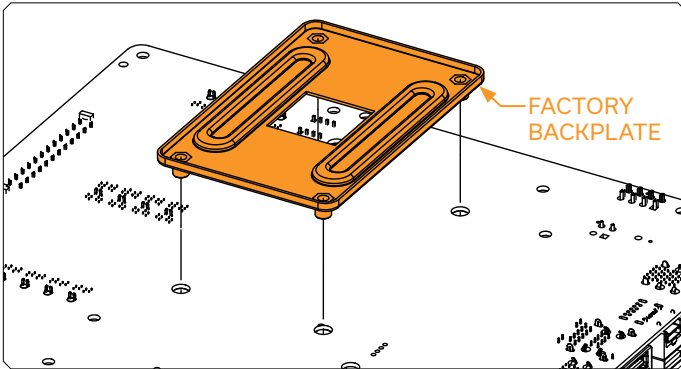
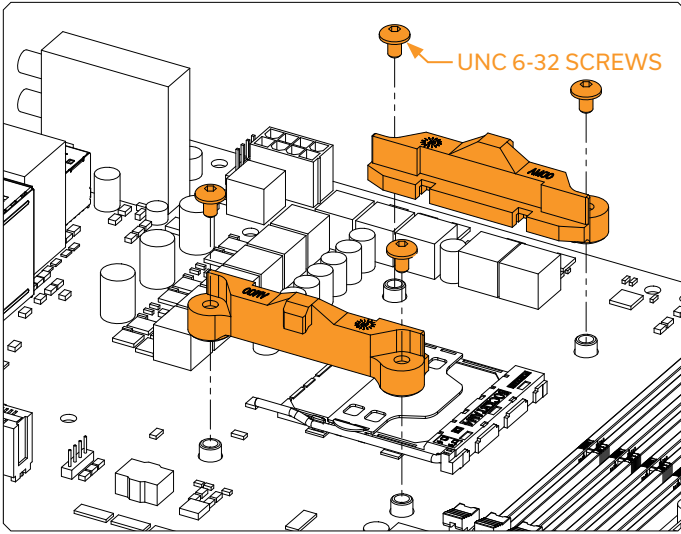

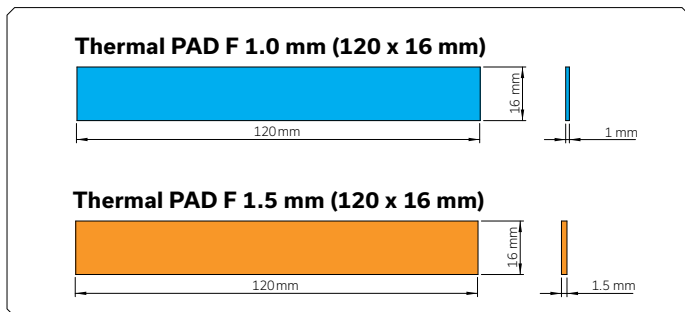

APPLYING THERMAL COMPOUND

Apply thermal compound on CPU heat spreader (IHS) with enclosed EK-TIM Ectotherm thermal grease. The quantity of about two rice grains is just about right. There is no need to cover the whole IHS. Applying too much thermal grease will have negative impact on the cooling performance!

CUTTING THERMAL PADS

Your block comes with thermal pads which needs to be trimmed in order to fit the voltage regulation area (MOSFET) on the motherboard's circuit board.

1. Thermal PAD F 1.0mm - (120 x 16 mm) EAN: 3830046996732
2. Thermal PAD F 1.5mm - (120 x 16 mm) EAN: 3830046996749

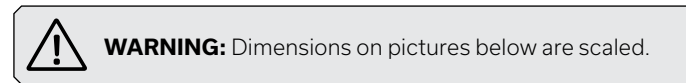

PLACING THERMAL PADS ON THE MOTHERBOARD

Place thermal pads on PCB as shown on the picture.

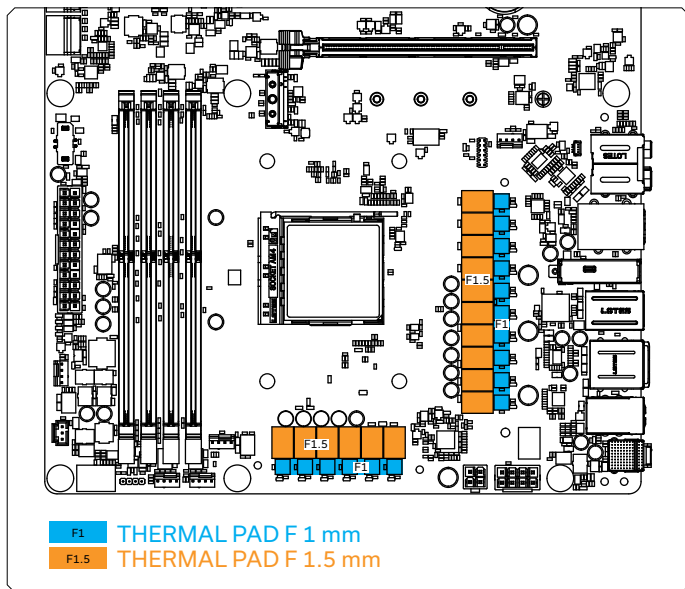
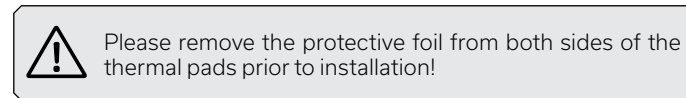

PLACING THE BLOCK ON TO MOTHERBOARD

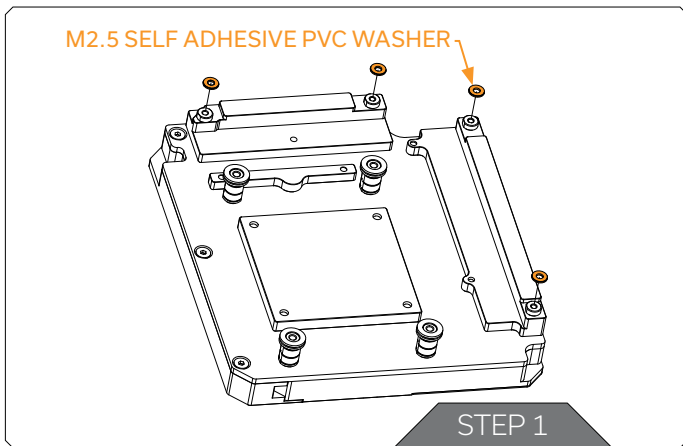

STEP 1

Install four (4) M2.5 self adhesive PVC washers under marked standoffs as shown on the picture below.

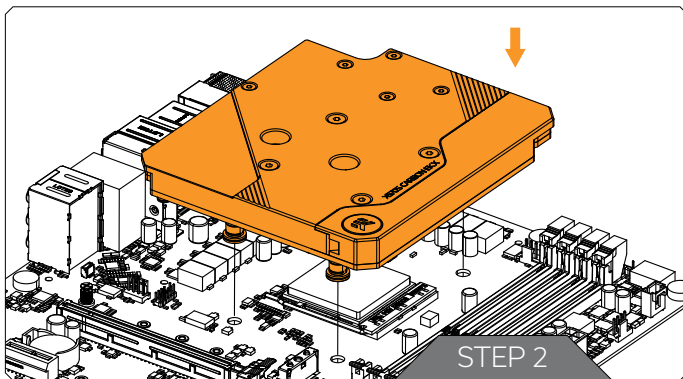

STEP 2

Place the MSI MPG X570S Carbon EK X Monoblock series water block to the motherboard or vice versa (as shown on the photo). Make sure that mounting holes are aligned.

ATTACHING BLOCK ON THE MOTHERBOARD

STEP 1

Prior to fastening the screws please make sure the mounting holes on the motherboard's circuit board are aligned with the water block.

Mosfet part: Use four (4) M2.5 x 5 AX1 Screws with PVC washers. Tighten the screws evenly. Do not use excessive force when tightening the screws.

CPU part: Use four (4) M3 x 10 DIN 7984 with screws. Tighten the screws using enclosed 2mm Allen Key.

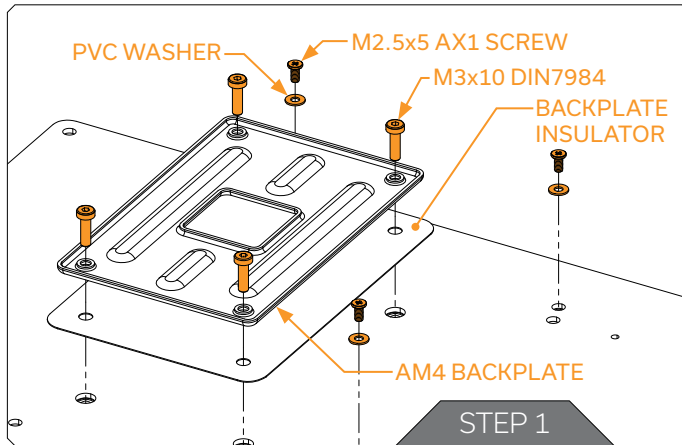
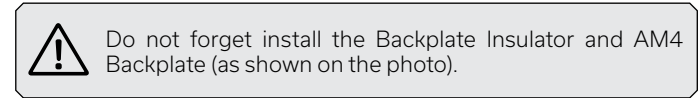

STEP 2

For the MSI MPG X570S Carbon EK X series water block to operate properly the G1/4 port nearest to the right edge of the water block **MUST BE USED AS THE INLET PORT.**

EK recommends the use of EK-Fittings. When using fittings other than EK series please use hose clamps or appropriate substitute to secure the tubing to the barb. The use of biocide containing and corrosion inhibiting coolant is always recommended for any liquid cooling system.

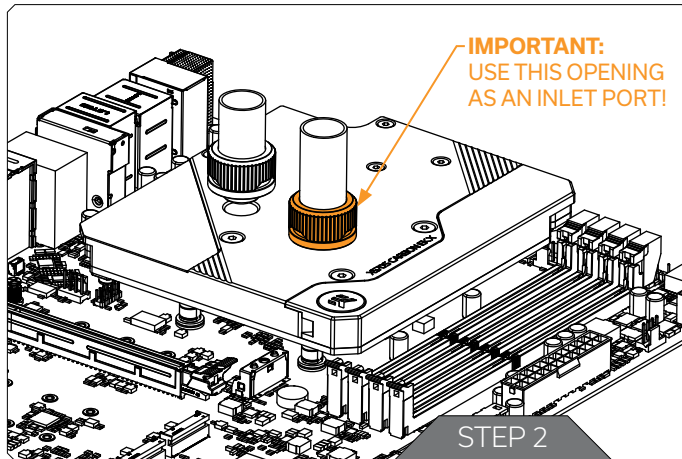

CONNECTING THE D-RGB LED STRIP

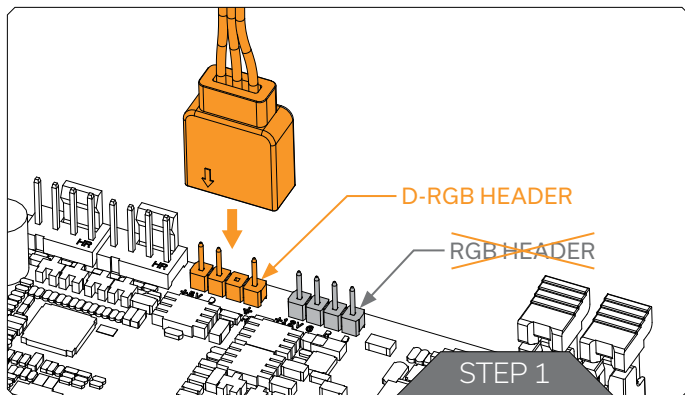

Plug the 3-pin connector from Monoblock D-RGB LED strip to the motherboard.



Please ensure that the arrow indicated on the connector is plugged into the +5V line as indicated on your motherboard. Failure to do so will damage your motherboard or LED strip.

REQUIRED TOOLS

Phillips-head screwdriver

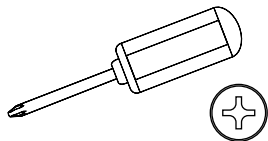

Scissors

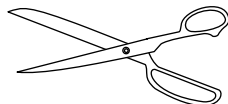

Allen Key

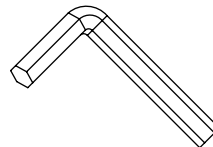

SUPPORT AND SERVICE

In case you need assistance or wish to order spare parts or a new mounting mechanism, please contact:

<https://www.ekwb.com/customer-support/>

For spare parts orders, refer to the page with "TECHNICAL SPECIFICATIONS AND PRODUCT PARTS" where you can find the EAN number of each part you might need.

Include the EAN number with quantity in your request. Mounting Mechanism EAN can be found under "BOX CONTENTS"

Thermal pads are readily available in the EK shop

SOCIAL MEDIA

 EKWaterBlocks

 @EKWaterBlocks

 ekwaterblocks

 EKWBofficial

 ekwaterblocks

