

# EK-Quantum Vector TRIO RTX 3080/3090 Active Backplate

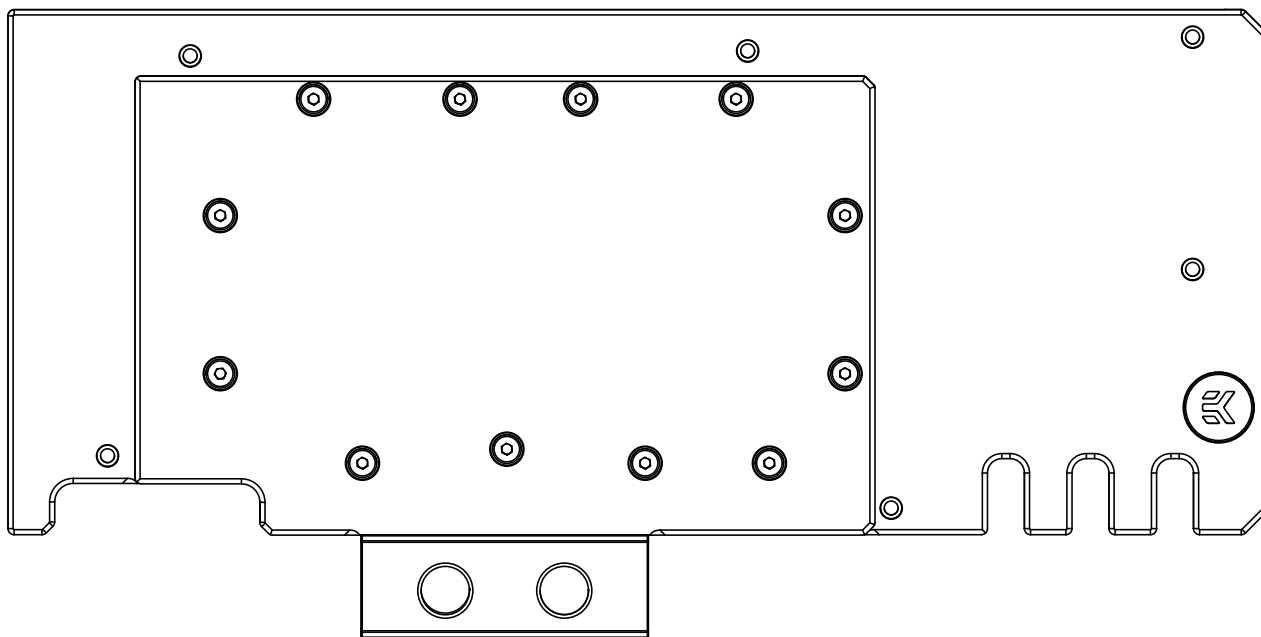

This product is intended for installation by expert users only. Please consult with a qualified technician. Improper installation may result in damage to your equipment. EK assumes no liability whatsoever, expressed or implied, for the use of this product or its installation. The following instructions are subject to change without notice. Please, read the manual carefully before beginning with the installation process. For updates, you can visit our official website [www.ekwb.com](http://www.ekwb.com).

Before you start using this product, please follow these basic guidelines:

**Carefully read the manual before beginning with the installation process.**

**Remove your graphics card from the computer for the safest mounting process to prevent any possible damage to your GPU or its circuit board (PCB).**

**EK Fittings require only a small amount of force to screw them firmly in place since the liquid seal is ensured with the rubber O-ring gaskets.**

**The use of quality market-proven corrosion-inhibiting coolants is always strongly recommended for any liquid cooling system.**

**Do not use pure distilled water as a cooling liquid! For best results, EK recommends the use of EK-CryoFuel Coolants.**

**Make sure to bleed air out of your water block thoroughly in order to reach optimal performance.**

**EK only guarantees compatibility with included EK-brand thermal pads. Installation process, cooling performance and block contacts are tested exclusively with EK-brand thermal pads. Listed thermal pad thicknesses apply only to thermal pads included in the package.**

**EK does not guarantee compatibility with aftermarket alternatives for thermal interface material.**

# TABLE OF CONTENTS

<b>BOX CONTENTS</b>	<b>4</b>
<b>ACTIVE BACKPLATE DIMENSIONS</b>	<b>5</b>
<b>REQUIRED TOOLS</b>	<b>5</b>
<b>TECHNICAL SPECIFICATIONS AND PRODUCT PARTS</b>	<b>6</b>
<b>INSTALLING THE ACTIVE BACKPLATE</b>	<b>7</b>
PREPARING THE GRAPHICS CARD	7
CUTTING AND PLACING THERMAL PADS	9
REMOVING THE TERMINAL METAL PLATE	10
ATTACHING THE ACTIVE BACKPLATE	10
<b>INSTALLING FITTINGS AND TUBING</b>	<b>12</b>
<b>CONNECTING THE D-RGB LED STRIP</b>	<b>12</b>
<b>TESTING THE LOOP</b>	<b>13</b>
<b>SUPPORT AND SERVICE</b>	<b>14</b>
<b>SOCIAL MEDIA</b>	<b>14</b>

# BOX CONTENTS

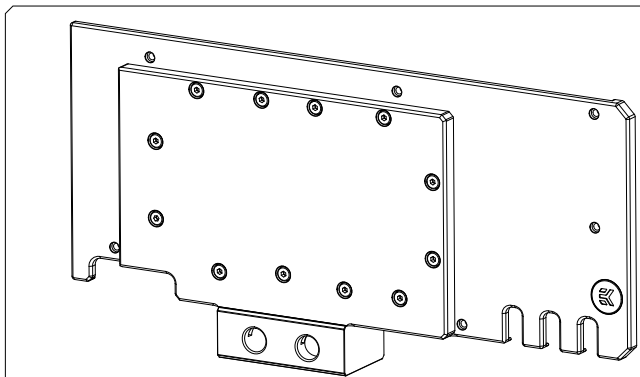

EK-Quantum Vector TRIO RTX 3080/3090 Active Backplate

**Mounting Mechanism** – You may not need all the screws, mounting mechanism is universal!

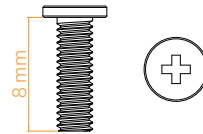

M2.5x8 AX1 Screw (8 pcs)

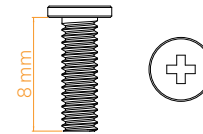

M2.5x8 AX1 Screw - Nickel (8 pcs)

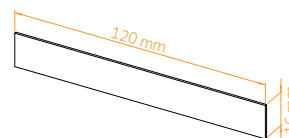

Thermal PAD F 1.0 mm - (120x16mm) (3 pcs)

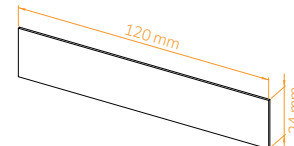

Thermal PAD G 2.0 mm - (120x24mm) (3 pcs)

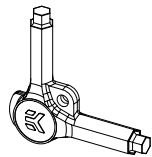

3830046996213 EK-Loop Multi Allen Key (6 mm, 8 mm, 9 mm) (1 pc)

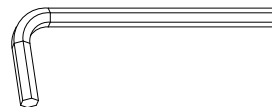

Allen Key 2.5 mm (1 pc)

## ACTIVE BACKPLATE DIMENSIONS

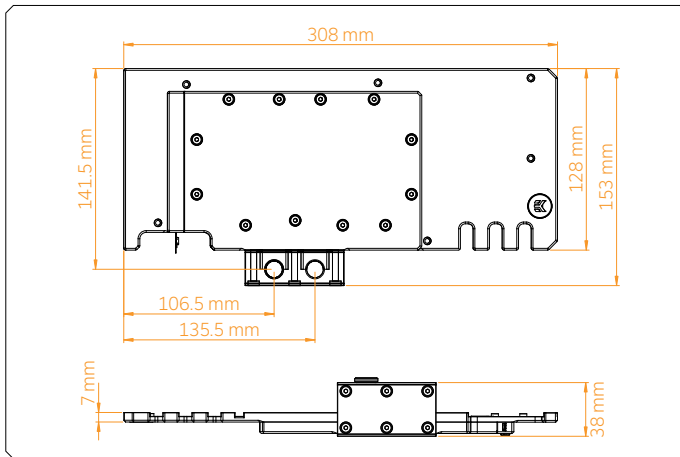

## REQUIRED TOOLS

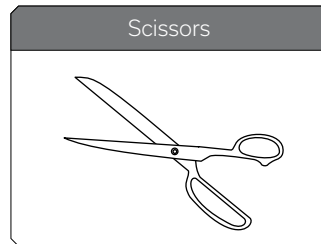

## TECHNICAL SPECIFICATIONS AND PRODUCT PARTS

### Technical Specification:

Dimensions (L x H x W): 308 x 153 x 38 mm

D-RGB (Addressable RGB) Cable Length: 500 mm

D-RGB LED Count: 5 (Plexi Version)

D-RGB Connector: Standard 3-Pin (+5V, Data, Blocked, Ground)

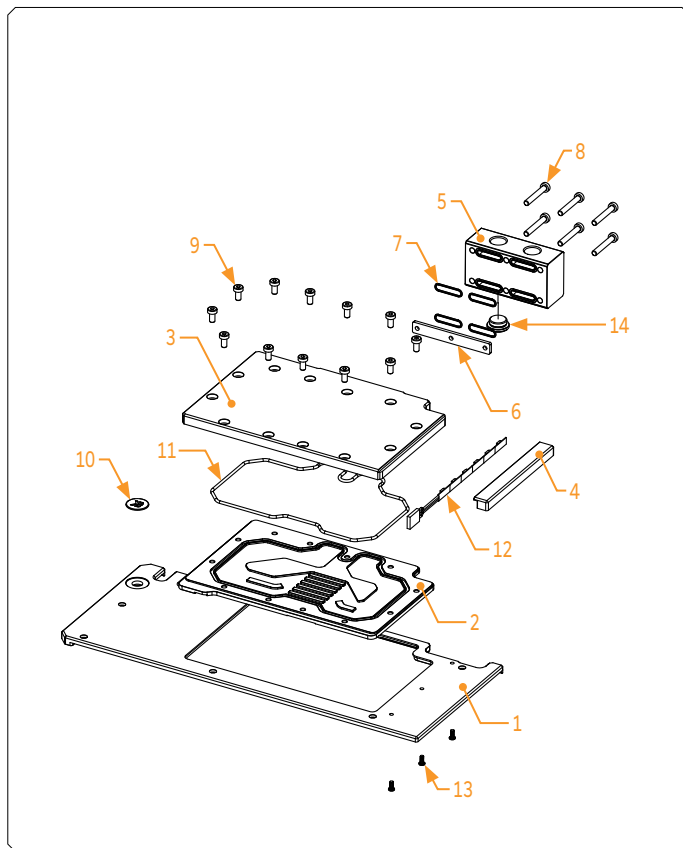

Position	EAN	Description	Quantity
1	104230	Alu cover (Ni)	1
	104231	Alu cover (Bl. elox)	
2	104233	Coldplate (Ni)	1
	104236	Top plate (Plexi)	
3	104237	Top plate (Acetal)	1
	104238	Standout (only for plexi version)	
4	104235	Plexi Terminal	1
	104234	Acetal Terminal	
6	4720	Terminal metal blank	1
7	5155	O-ring 15x1	4
8	100006	M4 x 27 DIN7984 Screw	6
	9013	M4 x 8 DIN7984 Screw	
10	100663	EK RGB Badge	1
11	104316	Main O-ring	1
12	100199	LED D-RGB Strip (only for plexi version)	1
13	9058	M2.5 x 6 AX1 Screw	3
14	102639	Plug G1/4	1

## INSTALLING THE ACTIVE BACKPLATE

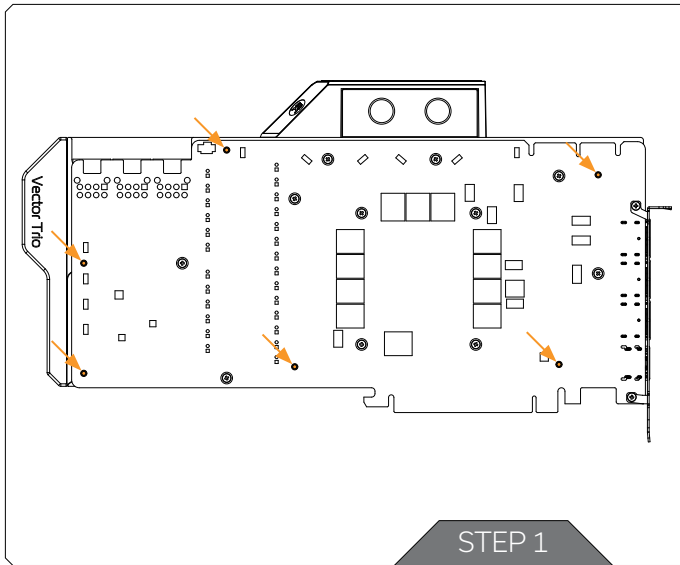

### STEP 1

#### PREPARING THE GRAPHICS CARD

First, complete the installation of your EK-Quantum Vector TRIO RTX 3080/3090 water block according to its installation manual. In case the water block is already installed, remove the six (6) AX1 screws and their PVC washers, as shown in the image.

For this Step, you will need:

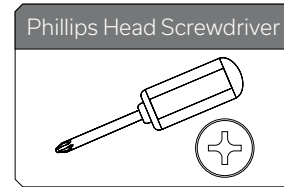

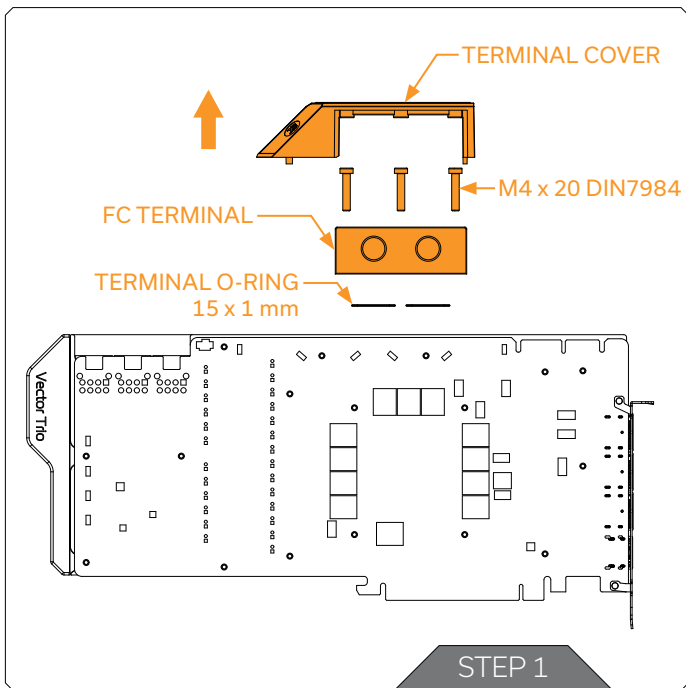

EK-Quantum Vector TRIO RTX 3080/3090 Active Backplate comes with its own terminal, meaning the original terminal, along with two (2) 15x1 O-rings, on the EK-Quantum Vector FTW3 3080/3090 water block has to be removed.

Unscrew the three (3) M4 x 20 DIN7984 screws and detach the terminal from the water block.

The procedure of the terminal detachment is shown below.



### Attention!

Attention! In case the EK-Quantum Vector TRIO 3080/3090 water block is already filled with coolant, empty the content of the water block before continuing with this step. Be careful that the coolant that remained in the water block does not come in contact with the GPU!

For this Step, you will need:

Allen Key 2.5 mm





### Thermal PAD F 1.0 mm (120 x 16 mm)



### Thermal PAD G 2.0 mm (120 x 24 mm)



STEP 2

## STEP 2

### CUTTING AND PLACING THERMAL PADS

Your backplate comes with thermal pads that have to be cut into smaller pieces to cover all the VRM components. EK made sure to provide you with more than an adequate quantity of thermal pads to complete these steps.

#### Replacement thermal pads:

Thermal PAD F 1.0 mm - (120 x 16 mm) - EAN: 3830046996732

Thermal PAD G 2.0 mm - (120 x 24 mm) - EAN: 3830046996794



EK only guarantees compatibility with included EK-brand thermal pads. Installation process, cooling performance and block contacts are tested exclusively with EK-brand thermal pads. Listed thermal pad thicknesses apply only to thermal pads included in the package.

EK does not guarantee compatibility with aftermarket alternatives for thermal interface material.

3080

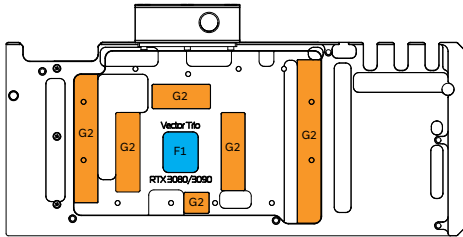

3090

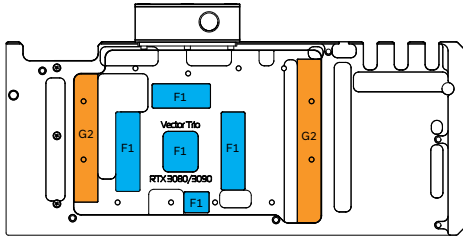

F1 Thermal Pad F 1 mm

G2 Thermal Pad G 2 mm

STEP 3

## STEP 3

Once cut to size, thermal pads should be placed on the backplate/PCB, as illustrated below.

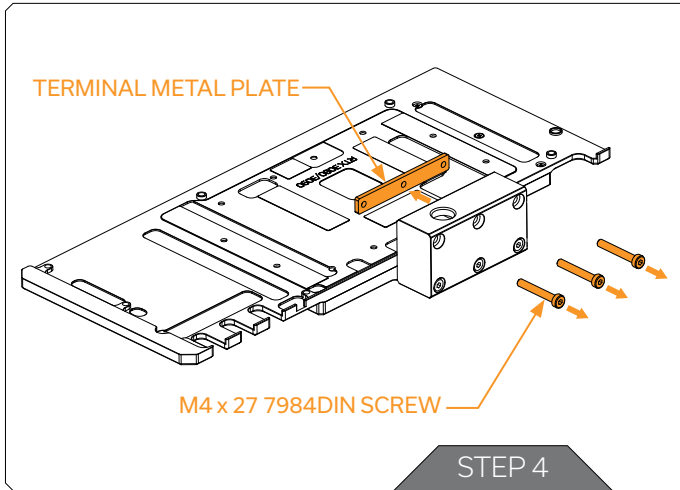

#### STEP 4 REMOVING THE TERMINAL METAL PLATE

The Metal plate attached on the Terminal is meant as a precaution, to secure the two O-rings to prevent them from falling out of their sockets during transport and handling. Before the installation of the Active Backplate, this metal plate has to be removed. Unscrew the three (3) M4 x 27 DIN7984 screws with the provided 2.5 mm Allen Key shown on the picture. Keep the screws as they will be needed in the upcoming step, unlike the metal plate which will not be needed anymore.

For this Step, you will need:

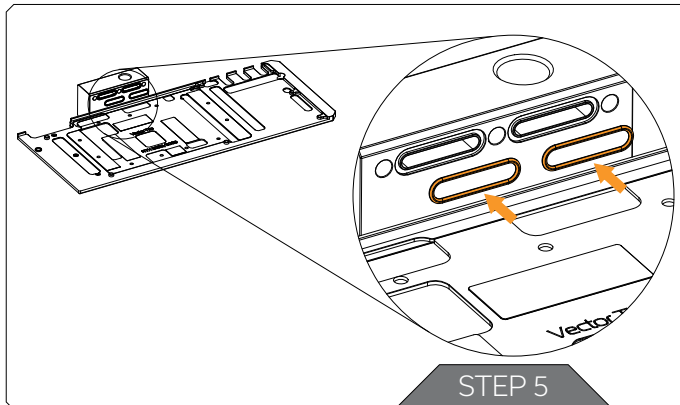
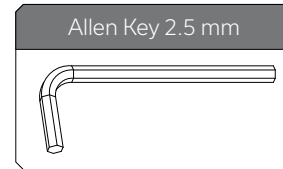

#### STEP 5 ATTACHING THE ACTIVE BACKPLATE

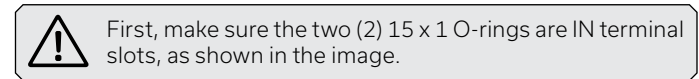

First, make sure the two (2) 15 x 1 O-rings are IN terminal slots, as shown in the image.

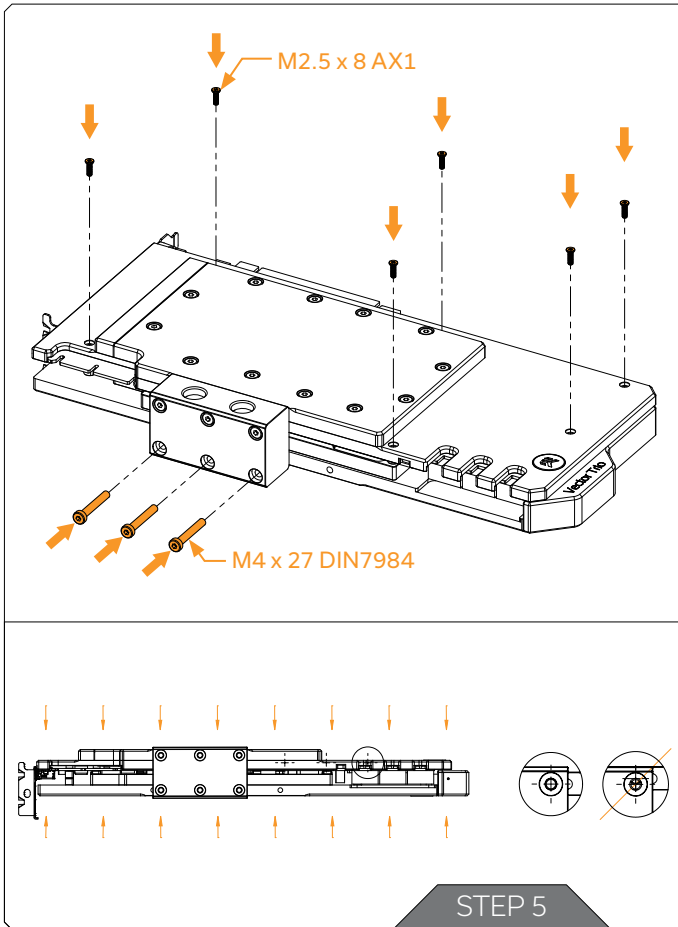

Place the active backplate on the PCB and make sure all holes are aligned. Position an M2.5 x 8 AX1 screw into each of the six (6) mounting holes (as shown in the image) and tighten them evenly with a Phillips head screwdriver.

To avoid using excessive force, you can easily loosen up the three (3) M4 x 27 7984DIN screws pre-installed on the terminal, but be careful that two (2) 15 x 1 O-rings remain in their terminal slots. Also, do not forget to tighten the three (3) loosed M4 x 27 7984DIN screws back after attaching the Active Backplate.

In order to ensure that the holes in the terminal and the block line up, the thermal pads near the terminal must be compressed. This can be achieved by squeezing the block and active backplate together. This will not damage the PCB as the mounted standoffs prevent contact at critical locations. This is the only way to guarantee the promised performance of the components.

Then, position the three (3) M4 x 27 7984DIN screws that were detached from the GPU water block terminal into each of the three (3) mounting holes (as shown in the image) and tighten them evenly with the provided 2.5 mm Allen Key.

### Do not use excessive force!



**CAUTION:** When placing the Active Backplate on the PCB, the two inserted 15 x 1 O-rings must remain inside their STEP 5 terminal slots. Wrongly positioned O-rings can cause leaks!

For this Step, you will need:

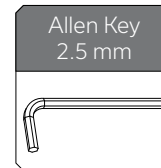
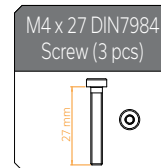
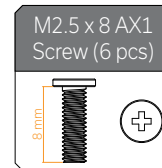

## INSTALLING FITTINGS AND TUBING

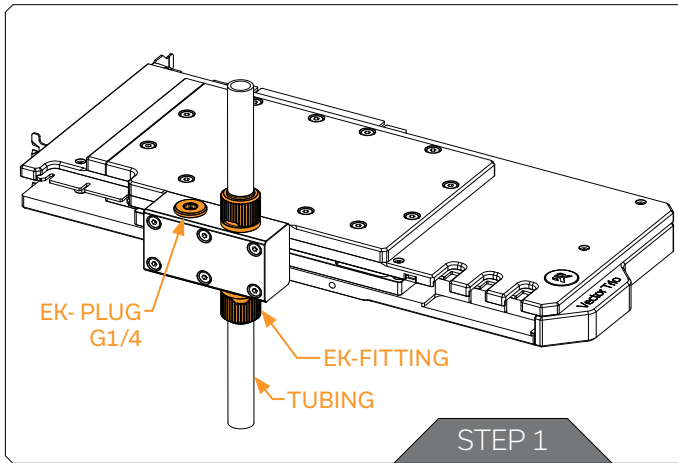

### STEP 1

Screw-in two (2) G1/4 threaded male fittings. Attach liquid cooling tubes and connect the water block to the cooling loop.

The pre-mounted terminal is positioned for the optimal flow in the EK-Quantum Vector Trio RTX 3080/3090 water block and in the EK-Quantum Vector Trio RTX 3080/3090 Active Backplate. The terminal can be shifted for 180 degrees but by using it so, the inlet and outlet ports are changed.

The plugged port is not mentioned to be used as inlet/outlet!

**EK recommends using EK fittings with all EK water blocks.**



**CAUTION:** When using connectors other than EK fittings, pay special attention to the length of the fittings' male G1/4" thread – 5 mm is the maximum G1/4" thread length allowed!

## CONNECTING THE D-RGB LED STRIP

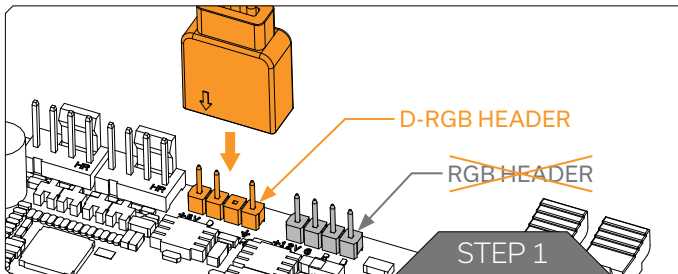

### STEP 1

Plug the **4-pin D-RGB** connector from the GPU water block to the **D-RGB Header** on your motherboard or controller. The LED strip will work only if the pin layout on the header is as follows: **+5V, Data, Empty, Ground**.



**Incorrect installation or installation to a wrong header can damage the LED strip or the header itself!**

## TESTING THE LOOP

To ensure the installation of EK components was successful, we recommend you perform a 24-hour leak test.

When your loop is complete and filled with coolant, connect the pump to a PSU outside your system. Do not connect power to any of the other components. Turn on the PSU and let the pump run continuously.

Inspect all parts of the loop, and in case the coolant leaks, fix the issue and repeat the testing process. To prevent possible damage, please ensure that all hardware is dry before the system is powered on.

## SUPPORT AND SERVICE

In case you need assistance or wish to order spare parts or a new mounting mechanism, please contact:

**<https://www.ekwb.com/customer-support/>**

For spare parts orders, refer to the page with "TECHNICAL SPECIFICATIONS AND PRODUCT PARTS" where you can find the EAN number of each part you might need.

Include the EAN number with quantity in your request. Mounting Mechanism EAN can be found under "BOX CONTENTS"

Thermal pads are readily available in the EK shop

## SOCIAL MEDIA

 EKWaterBlocks

 @EKWaterBlocks

 ekwaterblocks

 EKWBofficial

 ekwaterblocks

